

STATE OF RHODE ISLAND

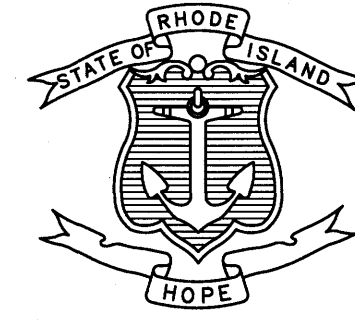

CITY OF CENTRAL FALLS
HONORABLE MAYOR MARIA RIVERA

PLANS OF PROPOSED

SYLVIAN STREET
INFRASTRUCTURE AND STREETScape IMPROVEMENTS

PROVIDENCE COUNTY
CONTRACT NO. 2021-0011

INDEX OF DRAWINGS

SHEET NO.	DESCRIPTION
1	COVER
2-3	STANDARD NOTES 1-2
4	JOB SPECIFIC GENERAL NOTES & LEGEND
5	TYPICAL SECTIONS
6-8	GENERAL PLAN NOS. 1-3
9-11	SIGNING & STRIPING PLAN NOS. 1-3
12-15	CHICANE DETAILS 1-4
16-19	CHICANE LANDSCAPE 1-4
20-21	DETAILS 1-2

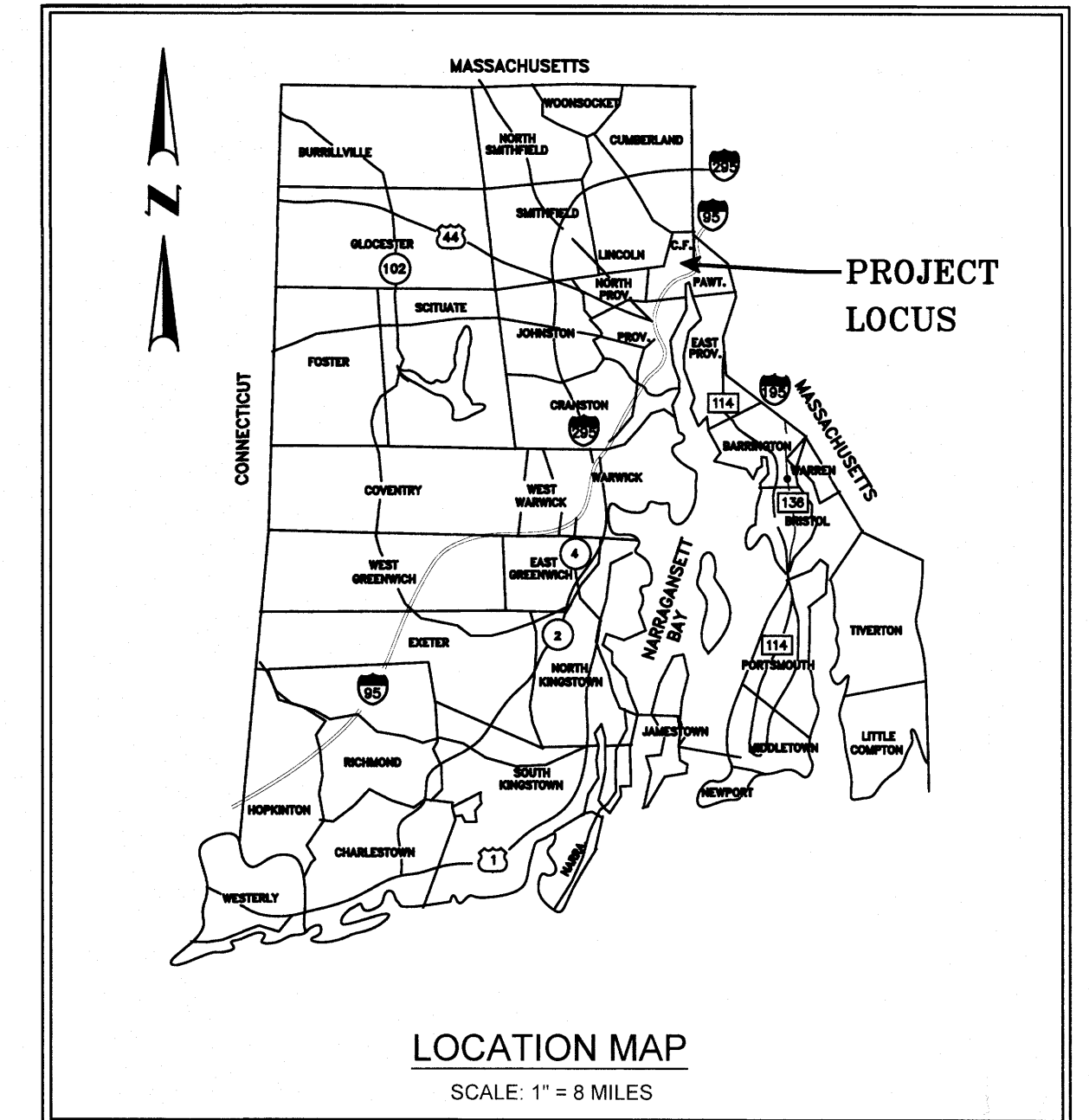

LAYOUT/KEY PLAN

SCALE: 1" = 100'

SCALE OF DRAWINGS

PLANS: 1 INCH = 20 FEET

BASE OF LEVELS

HORIZONTAL - NAD 83(2011) EPOCH - 2010.00
VERTICAL - NGVD 29

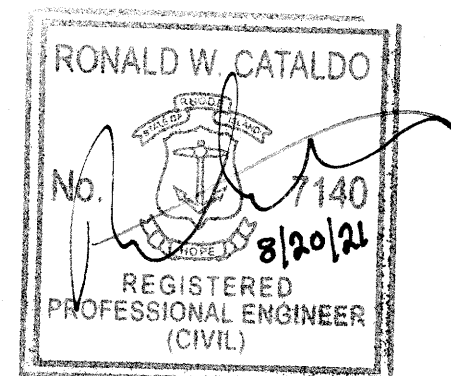

FINAL SUBMISSION
AUGUST 20, 2021

RHODE ISLAND SPECIFICATIONS AND STANDARD DETAILS

SPECIFICATIONS TO GOVERN THIS PROJECT ARE THE R.I. STANDARD SPECIFICATIONS FOR ROAD AND BRIDGE CONSTRUCTION, AMENDED MARCH 2018, WITH ALL REVISIONS, AND THE STATE AND FEDERAL SPECIAL PROVISIONS INCLUDED IN THE CONTRACT DOCUMENTS. STANDARD DETAILS FOR THIS PROJECT ARE R.I. STANDARD DETAILS, JUNE 21, 2019 EDITION, WITH ALL REVISIONS.



RA CATALDO & ASSOCIATES INC.
CIVIL ENGINEERS - LAND SURVEYORS

(401) 453-3300
FAX: (401) 453-4117
ca@cataldoeng.com

114 SMITHFIELD AVENUE
PAWTUCKET, RHODE ISLAND 02860

Contract Number 2021-0011
Number of Sheet 1
Total Sheets 21

GENERAL NOTES:

- ANY DAMAGE TO EXISTING PAVEMENT, BRIDGES, CONDUIT, SIDEWALK, FENCES, ETC., CAUSED BY THE CONTRACTOR SHALL BE REPAIRED BY THE CONTRACTOR AT NO ADDITIONAL COST TO THE STATE.
- THE CONTRACTOR SHALL PLACE ALL EQUIPMENT AND MATERIAL AS FAR AWAY AS POSSIBLE FROM THE EDGE OF THE TRAVEL LANE SO AS NOT TO CAUSE A SAFETY HAZARD, IN ACCORDANCE WITH SECTION 106.06 OF THE R.I.D.O.T. STANDARD SPECIFICATION, LATEST EDITION.
- IT IS THE CONTRACTOR'S RESPONSIBILITY TO ENSURE THAT THE EXISTING CONDITIONS ARE NOT OBLITERATED BEFORE CONTROL POINTS ARE LOCATED AND CONSTRUCTION LAYOUT IS ESTABLISHED. THE CONSTRUCTION LAYOUT SHALL BE PROVIDED IN SUFFICIENT DETAIL, THEREBY ENABLING HIM TO CONSTRUCT THE PROJECT IN CONFORMITY WITH THE PLANS AND SPECIFICATIONS. SURVEY WILL BE PROVIDED BY THE CONTRACTOR. THE RESIDENT ENGINEER WILL NOT AUTHORIZE CONSTRUCTION ACTIVITIES TO BEGIN UNTIL HE IS SATISFIED THAT ALL GROUND CONTROL HAS BEEN ESTABLISHED, TIED DOWN, AND DULY RECORDED IN STANDARD FIELD BOOKS.
- ALL R.I. STD. 9.9.0 CONSTRUCTION ACCESS ROADS SHALL BE CONSTRUCTED PRIOR TO ANY ROADWAY ACCEPTING CONSTRUCTION TRAFFIC.
- THE FREQUENCY AND APPLICATION RATES FOR THE DUST CONTROL ITEMS WILL BE AS DIRECTED BY THE ENGINEER.
- ALL SIDEWALK AND DRIVEWAYS DESIGNATED FOR REPLACEMENT SHALL BE CUT AND WATCHED AT LOCATIONS SHOWN ON THE PLANS OR AS DIRECTED BY THE ENGINEER.
- ASPHALT EMULSION TACK COAT SHALL BE PLACED PRIOR TO PAVEMENT PLACEMENT ON THE CONCRETE BASE OR COLD PLANNED PAVEMENT, AND ON ANY NEW COURSE WHICH HAS BEEN OPEN TO TRAFFIC, OR ANY NEW COURSE WHICH HAS BEEN EXPOSED FOR MORE THAN 3 DAYS, AND/OR AS DIRECTED BY THE ENGINEER. IT SHALL ALSO BE APPLIED TO VERTICAL PAVEMENT FACES BETWEEN ADJOINING PAVEMENT SECTIONS. ALL APPLICATIONS ON BOTH HORIZONTAL AND VERTICAL SURFACES SHALL BE PAID FOR UNDER THE CONTRACT UNIT BID PRICE FOR CODE 403.0300 "ASPHALT EMULSION TACK COAT."
- THE LIMITS OF CLEARING AND SURFACE DISTURBANCE MUST BE STRICTLY ADHERED TO IN ALL AREAS. IN ADDITION TO THOSE AREAS SPECIFICALLY DESIGNATED ON THE PLANS, THE CONTRACTOR WILL BE RESPONSIBLE FOR PROVIDING AND PLACING, AT HIS OWN EXPENSE, PLANTABLE SOIL AND SEED IN AREAS WHICH ARE OUTSIDE OF THE PROJECT'S AREAS OF DISTURBANCE AND WHICH ARE IMPACTED BY CONSTRUCTION OPERATIONS INCLUDING THOSE AREAS WHERE VEHICLES, EQUIPMENT AND MATERIALS ARE STORED WITH THE PERMISSION OF THE ENGINEER.
- UNDER NO CIRCUMSTANCE WILL THE CONTRACTOR BE ALLOWED TO STOCKPILE REMOVED PAVEMENT MATERIALS WITHIN THE PROJECT LIMITS.
- CLEANING AND SWEEPING OF PAVEMENT WILL INCLUDE REMOVAL OF ALL PAVEMENT DEBRIS PRIOR TO THE PLACEMENT OF EACH BITUMINOUS PAVEMENT LIFT. ALL CLEANING AND SWEEPING SHALL BE DONE TO THE SATISFACTION OF THE ENGINEER.
- PRIOR TO INSTALLATION, ALL SIGNS, MOUNTINGS AND LOCATIONS SHALL BE APPROVED OR MODIFIED BY THE ENGINEER.
- PAVEMENT OPERATIONS FOR CURBED SECTIONS: IN AREAS WHERE CURBING IS SET TO FINISH LINE AND GRADE, THE CONTRACTOR WILL NOT BE REQUIRED TO UTILIZE THE SENSOR AND SKY-TYPE DEVICE FOR AUTOMATIC GRADE CONTROL, BUT WILL BE ALLOWED TO MANUALLY ADJUST THE BITUMINOUS PAVER FOR CONTROLLING GRADE.
- THE CONTRACTOR SHALL BE RESPONSIBLE FOR MAINTAINING ALL ROADWAYS FREE OF DEBRIS RESULTING FROM THEIR CONSTRUCTION OPERATIONS. ALL DEBRIS SHALL BE REMOVED TO THE SATISFACTION OF THE ENGINEER AT NO ADDITIONAL COST TO THE STATE.
- NO FUEL STORAGE, VEHICLE REFUELING, OR EQUIPMENT STORAGE SHALL TAKE PLACE IN DESIGNATED WETLANDS, NOR WITHIN 100' OF ANY WATER BODY. THIS REQUIREMENT SHALL NOT SUPERSEDE ANY FEDERAL, STATE OR LOCAL LAW, ORDINANCE, RULE OR REGULATION THAT APPLIES TO THE SAME, UNLESS THIS REQUIREMENT IS MORE STRINGENT THAN SAID LAW, ORDINANCE, RULE OR REGULATION.
- THE CONTRACTOR SHALL BE RESPONSIBLE TO ENSURE THAT AT THE END OF FINAL PAVING OPERATIONS, FLOW TO EXISTING DRAINAGE STRUCTURES HAS BEEN REESTABLISHED AND THAT NO ISOLATED DEPRESSIONS REMAIN. THERE SHALL BE NO SEPARATE PAYMENT FOR THIS PROVISION; IT SHALL BE CONSIDERED INCIDENTAL TO PAVING AND COLD PLANING OPERATIONS.
- ALL EMBANKMENTS SHALL BE PLACED IN HORIZONTAL LAYERS NOT EXCEEDING 12" (AFTER COMPACTION) AND SHALL BE COMPACTED AS SPECIFIED BEFORE THE NEXT LAYER IS PLACED. ALSO, EMBANKMENT CONSTRUCTION SHALL CONFORM TO SECTION 202.03.2 OF THE R.I.D.O.T. STANDARD SPECIFICATIONS, LATEST EDITION.
- IF THIS PROJECT IS ON A HURRICANE EVACUATION AND DIVERSIONARY ROUTE, AS DESIGNATED ON THE COVERSHEET, THE CONTRACTOR IS ADVISED THAT UPON 12 (TWELVE) HOURS NOTICE THE ROADWAY SHALL BE OPEN TO EVACUEES AND EMERGENCY PERSONNEL. ANY EXTRA WORK NECESSARY TO COMPLY WITH THIS REQUIREMENT WILL BE REIMBURSED UNDER FORCE ACCOUNT PROCEDURES.
- THE CONTRACTOR SHALL READ, BECOME FAMILIAR WITH, AND ADHERE TO ALL OF THE PROVISIONS, CONDITIONS, AND STIPULATIONS STATED IN THE ENVIRONMENTAL APPROVALS ISSUED FOR THE PROJECT FROM THE DEPARTMENT OF ENVIRONMENTAL MANAGEMENT (RIDEM), AND/OR THE ARMY CORPS OF ENGINEERS (ACOE), AND/OR THE COASTAL RESOURCES MANAGEMENT COUNCIL (CRMC). COPIES OF EACH OF THESE PERMITS ARE INCLUDED IN THE CS PAGES OF THE CONTRACT DOCUMENTS. ALL COSTS ASSOCIATED WITH THESE CONDITIONS SHALL BE CONSIDERED INCIDENTAL TO THE CONSTRUCTION AND INCLUDED WITH THE COST FOR THE ASSOCIATED BID ITEM(S).
- FOR ALL PROJECTS INVOLVING KNOWN SITE REMEDIATION ISSUES, THE CONTRACTOR SHALL READ, BECOME FAMILIAR WITH, AND ADHERE TO ALL OF THE CONSTRUCTION RELATED PROVISIONS, CONDITIONS, AND STIPULATIONS OF ANY REMEDIAL PLANS DEVELOPED FOR THE PROJECT. COPIES OF THESE DOCUMENTS ARE INCLUDED IN THE CS PAGES OF THE CONTRACT DOCUMENTS. ALL COSTS ASSOCIATED WITH COMPLIANCE WITH THESE DOCUMENTS SHALL BE CONSIDERED INCIDENTAL TO THE CONSTRUCTION AND INCLUDED WITH THE COST FOR THE ASSOCIATED BID ITEM(S).
- NO UNPROTECTED CONSTRUCTED FEATURE MAY PROJECT MORE THAN 4 INCHES ABOVE THE FINISHED GRADE OF A TRAVERSABLE SLOPE IN A CLEAR ZONE, e.g. HEADWALL, DRAINAGE INLET, ETC.
- THE REMAINING SECTION OR STUB OF A BREAKAWAY BASE MAY NOT PROJECT MORE THAN 4 INCHES ABOVE THE FINISHED GRADE OF A TRAVERSABLE SLOPE IN A CLEAR ZONE, e.g. SIGN POSTS, LIGHT POLES, FIRE HYDRANTS, ETC.

DRAINAGE AND EROSION CONTROL NOTES:

- FOR ALL PROJECTS WITH AT LEAST ONE(1) ACRE OF SOIL DISTURBANCE. R.I.D.O.T. IS REQUIRED TO DEVELOP AND ENFORCE A SITE SPECIFIC STORM WATER POLLUTION PREVENTION PLAN (SWPPP) IN ORDER TO REMAIN IN COMPLIANCE WITH THE RIPDES GENERAL PERMIT FOR STORMWATER DISCHARGES ASSOCIATED WITH CONSTRUCTION ACTIVITIES. THE CONTRACTOR SHALL READ, BECOME FAMILIAR WITH, AND ADHERE TO ALL OF THE PROVISIONS, CONDITIONS, AND STIPULATIONS OF THE GENERAL PERMIT AND THE SITE SPECIFIC SWPPP FOR THIS PROJECT. COPIES OF THESE DOCUMENTS ARE INCLUDED IN THE CS PAGES OF THE CONTRACT DOCUMENTS. ALL COSTS ASSOCIATED WITH ADHERENCE TO THE SWPPP SHALL BE CONSIDERED INCIDENTAL TO THE CONSTRUCTION AND INCLUDED WITH THE COST FOR THE ASSOCIATED BID ITEM(S).
- NO UNDISTURBED AREAS SHALL BE CLEARED OF EXISTING VEGETATION AFTER OCTOBER 15 OF ANY CALENDAR YEAR OR DURING ANY PERIOD OF FULL OR LIMITED WINTER SHUTDOWN. ALL DISTURBED SOILS EXPOSED PRIOR TO OCTOBER 15 OF ANY CALENDAR YEAR SHALL BE SEEDED OR PROTECTED BY THAT DATE. ANY SUCH AREAS THAT DO NOT HAVE ADEQUATE VEGETATIVE STABILIZATION, AS DETERMINED BY THE RESIDENT ENGINEER OR ENVIRONMENTAL INSPECTOR, BY NOVEMBER 15 OF ANY CALENDAR YEAR, MUST BE STABILIZED THROUGH THE USE OF EROSION CONTROL MATTING OR HAY MULCH, IN ACCORDANCE WITH SPECIFICATIONS CONTAINED WITHIN THE R.I. SOIL EROSION AND SEDIMENT CONTROL HANDBOOK. IF WORK CONTINUES WITHIN ANY OF THESE AREAS DURING THE PERIOD FROM OCTOBER 15 THROUGH APRIL 15, CARE MUST BE TAKEN TO ENSURE THAT ONLY THE AREA REQUIRED FOR THAT DAY'S WORK IS EXPOSED, AND ALL ERODIBLE SOIL MUST BE RESTABILIZED WITHIN 5 WORKING DAYS. ANY WORK TO CORRECT PROBLEMS RESULTING FROM FAILURE TO COMPLY WITH THIS PROVISION SHALL BE THE RESPONSIBILITY OF THE CONTRACTOR. THERE WILL BE NO SEPARATE PAYMENT FOR THIS PROVISION, IT SHALL BE CONSIDERED INCIDENTAL TO CONSTRUCTION OPERATIONS. STABILIZATION OF ONE FORM OR ANOTHER AS DESCRIBED ABOVE SHALL BE ACHIEVED WITHIN 2 WEEKS OF FINAL GRADING.
- STOCKPILES OF MATERIAL SHALL NOT BE LOCATED WITHIN REGULATED WETLANDS OR BUFFER ZONE AREAS. THEY SHALL HAVE SIDE SLOPES NO GREATER THAN 30% AND STOCKPILES OF ERODABLE MATERIAL SHALL ALSO BE SEEDED AND RINGED WITH R.I. STD. 9.1.0 TO STABILIZE.
- IF THE PLANS INCLUDE SPECIFIC AREAS FOR PLACEMENT OF CONSTRUCTION DEWATERING BASINS AND/OR EQUIPMENT AND MATERIALS STORAGE AND STOCKPILING, AND IF THE CONTRACTOR ELECTS TO UTILIZE ANY OTHER AREAS FOR THESE PURPOSES, THIS SHALL BE APPROVED BY THE ENGINEER ONLY AFTER OBTAINING ANY NECESSARY PERMITS AND/OR PERMIT MODIFICATIONS FROM THE APPROPRIATE REGULATORY AUTHORITY(IES). ANY PERMITTING REQUIREMENTS SHALL BE THE RESPONSIBILITY OF THE CONTRACTOR AND SHALL BE ACCOMPLISHED AT NO COST TO THE STATE. THE ENGINEER WILL COORDINATE SUBMISSION OF ANY REQUIRED PERMIT APPLICATION MATERIALS WITH THE R.I.D.O.T. OFFICE OF ENVIRONMENTAL PROGRAMS.
- JUTE MESH SHALL BE USED TO STABILIZE PLANTABLE SOIL AND/OR LOAM IN ALL DITCHES, ON ALL SLOPES ADJACENT TO WETLANDS AND WETLAND PERIMETERS, AND ON ALL SLOPES WITHIN WATER QUALITY BASINS. JUTE MESH IN DITCHES SHALL EXTEND TO AN ELEVATION 2 FEET ABOVE THE BOTTOM OF THE DITCH.
- SEEDING ON ALL SLOPES 3 TO 1 OR STEEPER SHALL CONSIST OF THE FOLLOWING APPLICATIONS UNLESS CHANGED IN THE CONTRACT.
 - SEEDING TYPE I.
 - ADHESIVE MULCH STABILIZER
- UNVEGETATED SLOPES SHALL NOT BE UNATTENDED OR EXPOSED FOR PERIODS IN EXCESS OF 2 WEEKS OR THROUGH THE INACTIVE WINTER SEASON.
- PRIOR TO DRAINAGE AND UTILITY CONSTRUCTION, THE CONTRACTOR IS RESPONSIBLE FOR VERIFYING THE LOCATION (HORIZONTAL AND VERTICAL) OF ALL EXISTING PIPES AND/OR STRUCTURES WHICH ARE TO BE CONNECTED. ANY VARIATION FOUND FROM THE PLANS MUST BE BROUGHT TO THE ENGINEER'S ATTENTION PRIOR TO DRAINAGE AND UTILITY CONSTRUCTION. WORK CAN COMMENCE ONLY UPON THE ENGINEER'S AUTHORIZATION.
- ALL DRAINAGE AND UTILITY STRUCTURES WITHIN THE PAVED ROADWAY SHALL BE ADJUSTED TO GRADE WITH THE SURROUNDING PAVEMENT PRIOR TO THE WINTER SHUTDOWN.
- DURING CONSTRUCTION, THE CONTRACTOR SHALL BE RESPONSIBLE FOR MAINTAINING DRAINAGE AND RUNOFF FLOW DURING STORMS AND PERIODS OF RAINFALL THROUGHOUT THE WORK AREA.
- CATCH BASIN RIM GRADES NOTED ON PLANS ARE DEPRESSED 0.1' LOWER THAN THE GUTTER GRADE. RIM ELEVATIONS SHOWN ARE FINAL GRADES. THE CONTRACTOR SHALL PLACE FRAMES AND GRATES 0.1' BELOW THE GRADE CONSTRUCTED IN THIS CONTRACT OR AS DIRECTED BY THE ENGINEER.
- PROVISIONS FOR CLEARING TO ACCESS OUTFALLS DURING THE CLEANING AND FLUSHING OF THE CLOSED DRAINAGE SYSTEM SHALL BE KEPT TO A MINIMUM.
 - ANY VEGETATIVE CLEARING SHALL BE LIMITED TO BRUSH AND TREES LESS THAN 3" DIAMETER.
 - NO HEAVY EQUIPMENT MAY ENCR OACH UPON VEGETATED PERIMETER OR RIVERBANK WETLANDS AS WELL AS BIOLOGICAL WETLANDS.
- THE CONTRACTOR SHALL INSTALL ALL EROSION CONTROL DEVICES FOR OUTLET PROTECTION PRIOR TO CLEANING AND FLUSHING STORM WATER DRAINAGE. EROSION CONTROL DEVICES SHALL REMAIN IN PLACE UNTIL ALL FLUSHED SEDIMENTS ARE REMOVED. AT ALL OUTFALL LOCATIONS WHERE PIPES ARE TO BE CLEANED AND FLUSHED, OUTLET PROTECTION (R.I. STD. 9.1.0 OR 9.3.0) SHALL BE INSTALLED TO TRAP SEDIMENTS. THESE SEDIMENTS SHALL THEN BE REMOVED AND DISPOSED OF LEGALLY BEFORE THE OUTLET PROTECTION DEVICES ARE REMOVED. IF OUTLET PROTECTION AT THE OUTFALL IS NOT FEASIBLE, THEN THE OUTLET PIPE OF THE LAST DRAINAGE STRUCTURE TO BE CLEANED SHALL BE PLUGGED TO CAPTURE ALL MATERIALS FLUSHED FROM PIPES. AFTER THE MATERIALS ARE REMOVED FROM THE DRAINAGE STRUCTURE, THE OUTLET SHALL BE UNPLUGGED TO RESUME NORMAL FUNCTIONING.
- R.I. STD. 9.8.0 BALED HAY INLET PROTECTION SHALL BE INSTALLED AT ALL CATCH BASINS AND INLETS WHENEVER SUBBASE IS EXPOSED, AND SHALL REMAIN IN PLACE UNTIL THE ABUTTING GROUND SURFACES ARE STABILIZED.
- WHERE BALED HAY INLET PROTECTION AND SILT FENCES ARE USED AT CATCH BASINS, THEY SHALL BE REMOVED AT THE END OF THE PROJECT OR AS DIRECTED BY THE ENGINEER IN ORDER TO PREVENT CLOGGING OF THE INLET.

DRAINAGE AND EROSION CONTROL NOTES (CONTINUED):

- DETENTION AND RETENTION BASINS MAY BE ROUGH GRADED AND STABILIZED WITH VEGETATION AND/OR OTHER EROSION CONTROL MEASURES AS REQUIRED BY THE ENGINEER PRIOR TO USE AS TEMPORARY SEDIMENTATION BASINS DURING PROJECT CONSTRUCTION. FINAL BASIN CONSTRUCTION SHALL NOT COMMENCE UNTIL ALL SOURCES OF SEDIMENT HAVE BEEN ELIMINATED. FINAL ROADSIDE VEGETATION IS ESTABLISHED AND USE OF TEMPORARY BASINS IS NO LONGER REQUIRED AS DIRECTED BY THE ENGINEER. ANY ISSUES RELATING TO EROSION AND/OR SEDIMENT TRANSPORT INTO WETLAND AREAS RESULTING FROM SUCH USE OF SEDIMENTATION BASINS DURING CONSTRUCTION SHALL BE THE RESPONSIBILITY OF THE CONTRACTOR. ANY CORRECTIVE ACTION REQUIRED TO RESOLVE SUCH ISSUES SHALL BE COMPLETED BY THE CONTRACTOR.
- THE TOE OF ANY FILL SLOPE IS TO REMAIN AT LEAST 1' INSIDE OF ALL EROSION CONTROLS. UNDER NO CIRCUMSTANCES SHALL THE CONTRACTOR COVER ANY PORTION OF THE EROSION CONTROL MEASURES WITH MATERIAL. ANY MATERIAL THAT IS PLACED ON ANY EROSION CONTROLS BY THE CONTRACTOR, OR ANY AGENT OF THE CONTRACTOR, SHALL BE IMMEDIATELY REMOVED BY THE CONTRACTOR, AND ANY NECESSARY REPAIRS TO THE EROSION CONTROLS ACCOMPLISHED.
- PRIOR TO COMMENCING CONSTRUCTION ACTIVITIES, EROSION AND SEDIMENTATION CONTROLS SHALL BE INSTALLED AT THOSE AREAS INDICATED ON THE PLANS. CLEARING MAY OCCUR PRIOR TO INSTALLATION OF SUCH CONTROLS, HOWEVER NO GRUBBING, GRADING, FILLING, OR OTHER SOIL DISTURBANCE SHALL OCCUR PRIOR TO INSTALLATION. THE LIMITS OF CLEARING AND SURFACE DISTURBANCE MUST BE STRICTLY ADHERED TO IN ALL AREAS.
- ALL HAY BALES, SILT FENCE OR TEMPORARY PROTECTION SHALL REMAIN IN PLACE UNTIL AN ACCEPTABLE STAND OF GRASS IS ESTABLISHED. IF NEEDED, TEMPORARY SEEDING CAN HELP TO MINIMIZE EROSION. TEMPORARY SEED WILL CONFORM TO R.I.D.O.T. STANDARD TEMPORARY SEED MIX.
- THE CONTRACTOR MUST REPAIR AND/OR RESEED ANY AREAS THAT DO NOT DEVELOP WITHIN THE PERIOD OF ONE YEAR AND HE SHALL DO SO AT NO ADDITIONAL EXPENSE TO THE STATE.
- THE NORMAL ACCEPTABLE SEASONAL SEEDING DATES ARE SPECIFIED IN SUBSECTION L.02.03 OF THE R.I.D.O.T. STANDARD SPECIFICATIONS, LATEST EDITION.
- ADDITIONAL EROSION CONTROLS, SHALL BE INSTALLED AS DIRECTED BY THE RESIDENT ENGINEER. THESE ADDITIONAL ITEMS WILL BE PAID AT THE UNIT PRICE FOR THAT BID ITEM.

UTILITY NOTES:

- EXISTING UTILITIES HAVE BEEN SHOWN ON THE PLANS USING THE BEST AVAILABLE INFORMATION AND ARE APPROXIMATE. BUILDING SERVICE CONNECTIONS (ELECTRIC, GAS, TELEPHONE, WATER AND SANITARY) ARE NOT SHOWN. CONTRACTOR IS TO ASSUME SERVICES ARE PRESENT TO ALL BUILDINGS.
- THE CONTRACTOR SHALL VERIFY THE LOCATIONS OF ALL EXISTING DRAINAGE AND UTILITIES BOTH UNDERGROUND AND OVERHEAD BEFORE EXCAVATION BEGINS IN ACCORDANCE WITH CHAPTER 39-1.2 OF THE R.I. GENERAL LAWS ENTITLED "EXCAVATION NEAR UNDERGROUND UTILITY FACILITIES", WITH AMENDMENTS EFFECTIVE AS OF NOVEMBER 1, 2009 AND, WHEN NECESSARY, BY CONTACTING THE INDIVIDUAL UTILITY COMPANIES. EXCAVATION SHALL BE IN ACCORDANCE WITH ALL STATUTES, ORDINANCES, RULES AND REGULATIONS OF ANY APPLICABLE CITY, TOWN, STATE OR FEDERAL AGENCY. THE CONTRACTOR SHOULD UNDERSTAND THAT NOT ALL UTILITIES SUBSCRIBE TO THE DIG SAFE PROGRAM. IT IS THE CONTRACTOR'S RESPONSIBILITY TO NOTIFY ALL UTILITY COMPANIES AND ENSURE THAT ALL UTILITIES HAVE BEEN MARKED PRIOR TO COMMENCING THEIR WORK. ANY DAMAGE TO EXISTING UTILITIES MARKED IN THE FIELD, OR AS A RESULT OF FAILING TO CONTACT THE APPROPRIATE UTILITY COMPANY, SHALL BE REPAIRED OR REPLACED AT NO ADDITIONAL COST TO THE STATE.
- ALL EXISTING UTILITIES TO BE ABANDONED SHALL BE CAPPED.
- EXISTING WATER SERVICES SHALL BE RECONNECTED TO THE NEW WATER MAINS.
- UTILITY SERVICE CONNECTIONS SHALL BE MAINTAINED TO ALL EXISTING FACILITIES TO REMAIN.
- FIRE HYDRANTS SHALL NOT BE REMOVED FROM SERVICE WITHOUT WRITTEN AUTHORIZATION FROM THE FIRE DEPARTMENT OR THE WATER AUTHORITY.
- ALL NEW WATER LINES SHALL BE DISINFECTED TO THE SATISFACTION OF THE WATER AUTHORITY IN ACCORDANCE WITH THE SPECIFICATIONS.
- ALL UTILITY POLE RELATED WORK SHALL BE BY OTHERS.

THIS PLAN SHALL NOT BE ALTERED

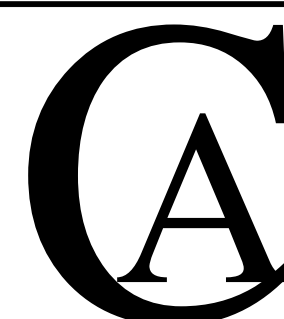

RA CATALDO & ASSOCIATES INC.
CIVIL ENGINEERS - LAND SURVEYORS

(401) 453-3300
FAX: (401) 453-4117
cc@cataldoeng.com

114 SMITHFIELD AVENUE
PAWTUCKET, RHODE ISLAND 02860



**CITY OF
CENTRAL FALLS**

DESIGNED BY:
CHECKED BY:
DATE:
SHEET: 2
OF: 21

SCALE: NO SCALE

REVISIONS			REVISIONS		
NO.	DATE	BY	NO.	DATE	BY
1	4/07	TRB			
2	3/10	RBH			

INFRASTRUCTURE AND STREETScape IMPROVEMENTS
SYLVIAN STREET
CONTRACT: 2021-0011
CENTRAL FALLS RHODE ISLAND

STANDARD NOTES 1

LANDSCAPE NOTES:

1. ALL PLANT MATERIAL MUST BE TAGGED AT THE NURSERY (A RECOGNIZED GROWER OF PLANT MATERIAL) IN ACCORDANCE WITH THE R.I.D.O.T. STANDARD SPECIFICATIONS, LATEST EDITION. ALL PLANT MATERIAL MUST BE NURSERY GROWN; NO PLANTATION GROWN PLANT MATERIAL WILL BE ACCEPTED.
2. ALL PLANT SUBSTITUTIONS AND/OR CHANGES IN PLANT LOCATION MUST BE APPROVED IN ACCORDANCE WITH THE R.I.D.O.T. STANDARD SPECIFICATIONS, LATEST EDITION.
3. ALL PLANT MATERIAL IS TO BE FIELD LOCATED BY A REPRESENTATIVE FROM THE R.I.D.O.T. LANDSCAPE ARCHITECTURE UNIT.
4. A R.I.D.O.T. LANDSCAPE REPRESENTATIVE MUST BE ON SITE TO APPROVE ALL TRIMMING AND CLEARING NECESSARY TO COMPLETE THE WORK AS SHOWN ON THE PLANS.
5. ANY TOPSOIL USED AS PLANTABLE SOIL SHALL HAVE A SANDY LOAM TEXTURE RELATIVELY FREE OF SUBSOIL MATERIAL, STONES, ROOTS, LUMPS OF SOIL, TREE LIMBS, TRASH OR CONSTRUCTION DEBRIS, AND SHALL CONFORM TO SECTION M.18 OF THE R.I.D.O.T. STANDARD SPECIFICATIONS, LATEST EDITION.
6. ALL TREES AND SHRUBS SHALL BE MULCHED WITH PINE BARK MULCH IN ACCORDANCE WITH THE R.I.D.O.T. STANDARD SPECIFICATIONS, LATEST EDITION.
7. ALL TREES AND/OR SHRUBS THAT ARE PLANTED AS A BED SHALL BE MULCHED AS A BED.
8. PROVIDE A MINIMUM 6'-8" BRANCHING STANDARD ON ALL TREES INSTALLED ADJACENT TO SIDEWALKS AND/OR PEDESTRIAN ACCESS AREAS.

**STRUCTURAL NOTES FOR HIGHWAY SIGNS,
LUMINAIRES AND TRAFFIC SIGNALS:**

GENERAL

1. ALL SUPPORT DESIGNS AND ASSOCIATED SHOP DRAWING REVIEWS SHALL BE IN CONFORMANCE WITH THE LATEST EDITION, OF THE AASHTO STANDARD SPECIFICATIONS FOR STRUCTURAL SUPPORTS FOR HIGHWAY SIGNS, LUMINAIRES AND TRAFFIC SIGNALS (THE "SPECIFICATIONS"), INCLUDING THE LATEST INTERIM SPECIFICATIONS, EXCEPT AS MODIFIED HEREIN.

CONSTRUCTION DRAWINGS AND DETAILS

1. THE FOLLOWING NOTES SHALL BE INCLUDED ON ALL PLANS AND/OR SHOP DRAWINGS IN REFERENCE TO ANCHOR BOLTS:
 - "PRETENSIONING OF ALL ANCHOR NUTS IS REQUIRED, AND SHALL BE ACCOMPLISHED BY TIGHTENING TO 1/6TH TURN BEYOND THE SNUG-TIGHT POSITION."
 - "THE MAXIMUM CLEARANCE BETWEEN THE BOTTOM OF THE LEVELING NUTS AND THE TOP OF THE CONCRETE IS CRITICAL AND SHALL NOT EXCEED THE AMOUNT SPECIFIED ON THIS DRAWING."
2. THE USE OF GROUT UNDER BASE PLATES SHALL GENERALLY NOT BE PERMITTED. IF SPECIFIC CONDITIONS WARRANT ITS USE, THE GROUT SHALL NOT BE CONSIDERED LOAD CARRYING; LOADS SHALL BE DIRECTLY SUPPORTED BY THE ANCHOR BOLTS. ADEQUATE DRAINAGE SHALL BE PROVIDED.
3. THE DAMPENING EFFECTS OF VIBRATION MITIGATION DEVICES SHALL NOT BE CONSIDERED IN THE DESIGN OF STRUCTURAL SUPPORTS FOR SIGNS AND TRAFFIC SIGNALS. IF THE CONTRACTOR CHOOSES TO USE THESE DEVICES FOR WARRANTY PURPOSES, THE TYPE OF DEVICES PROPOSED SHALL BE APPROVED BY THE DEPARTMENT PRIOR TO FABRICATION OF SUPPORTS.

TRAFFIC SIGNAL NOTES:

1. ALL SALVAGED TRAFFIC SIGNAL EQUIPMENT SHALL BE DELIVERED TO THE R.I.D.O.T. MAINTENANCE HEADQUARTERS, 360 LINCOLN AVENUE, WARWICK, RHODE ISLAND, 02888.
2. BACK PLATES SHALL BE INSTALLED ON ALL TRAFFIC SIGNAL HEADS.
3. THE CONTRACTOR SHALL SUPPLY AND INSTALL ON THE UPPER LEFT HAND CORNER OF THE BACK OF THE CONTROLLER CABINET DOOR A LAMINATED INTERSECTION GRAPHIC AND TABLE DEPICTING THE TRAFFIC DETECTOR RELAY CHANNEL ASSIGNMENTS. THE DIAGRAM SHALL BE A GRAPHIC OF THE INDIVIDUAL INTERSECTION ORIENTED SIMILAR TO THE PLANS SHOWING THE LOCATIONS OF EACH OF THE LOOP DETECTORS. THE DIAGRAM SHALL, AT A MINIMUM, INCLUDE DETECTOR NUMBERS, STREET NAME LABELS, NORTH ARROW, AND CONTROLLER CABINET LOCATION. THE ASSIGNMENT INFORMATION SHALL BE INCLUDED IN A TABLE WHICH SHALL INCLUDE, AT A MINIMUM, THE APPROACH NAME, DETECTOR NUMBER, TERMINAL NUMBER, DETECTOR RACK SLOT NUMBER, RELAY NUMBER, RELAY CHANNEL NUMBER, AND PHASE ASSOCIATED WITH EACH DETECTOR.
4. TRAFFIC CONTROLLER CABINETS, UNLESS OTHERWISE NOTED, SHALL BE NEMA TS2 TYPE 1 CABINET SIZE 6 ("P" TYPE) WITH NOMINAL DIMENSIONS OF 52"Hx44"Wx24"D.
5. ALL DELAY AND EXTENSION TIMES, AS CALLED FOR ON THE PLANS, FOR PROPOSED LOOP DETECTORS SHALL BE PROGRAMMED IN THE TRAFFIC SIGNAL CONTROLLER AND NOT THE DETECTOR RELAY.
6. A BARE GROUND WIRE SHALL BE PLACED IN ALL PVC CONDUITS AND SHALL BE BONDED TO GROUND RODS IN ACCORDANCE WITH SECTION T.03 OF THE RHODE ISLAND DEPARTMENT OF TRANSPORTATION STANDARD SPECIFICATIONS FOR ROAD AND BRIDGE CONSTRUCTION.
7. THE FINAL POSITION OF SIGNAL HEADS, PEDESTRIAN PUSHBUTTONS, DETECTORS, AND STOP LINE AND CROSSWALK PAVEMENT MARKINGS SHALL BE AS DIRECTED BY THE ENGINEER IN THE FIELD ACCORDING TO ACTUAL INTERSECTION CHARACTERISTICS.
8. A 2' MINIMUM BUFFER SHALL BE PROVIDED BETWEEN THE CURB AND ALL LATERAL OBSTRUCTIONS (INCLUDING ALL SIGNAL POLES AND TRAFFIC/PEDESTRIAN SIGNAL HEADS) TO PROVIDE ADEQUATE CLEARANCE FOR TURNING VEHICLES.
9. ALL FOUNDATIONS MUST HAVE CONES OR BARRELS BOLTED TO FOUNDATION BASES UNTIL ACTUAL POLE IS INSTALLED.
10. WHEN PLACING TRAFFIC SIGNAL HANDHOLES OR CONDUIT IN EXISTING PORTLAND CEMENT CONCRETE SIDEWALKS, THE ENTIRE SIDEWALK SQUARE OF CONCRETE SHALL BE REPLACED IN ACCORDANCE WITH R.I. STD. 43.1.0. NO PATCHES WILL BE ALLOWED.
11. ALL PEDESTRIAN PUSHBUTTONS SHALL BE COMPLIANT WITH "THE AMERICANS WITH DISABILITIES ACT ACCESSIBILITY GUIDELINES FOR BUILDINGS AND FACILITIES" (ADAAG) AND SHALL INCLUDE A PRESSURE-ACTIVATED (NON-MOVING) BUTTON. SIGNS APPLICABLE TO PUSHBUTTON ACTUATION SHALL BE INSTALLED SUCH THAT THE CROSSING ASSIGNED TO EACH BUTTON IS CLEARLY INDICATED. IF SITE CONDITIONS DO NOT ALLOW PEDESTRIAN PUSHBUTTONS TO BE INSTALLED WHERE CALLED FOR ON THE PLANS, THE R.I.D.O.T. TRAFFIC ENGINEERING UNIT SHALL BE CONSULTED WITH THROUGH AN R.F.I. PRIOR TO INSTALLING THE PUSHBUTTONS. THE FINAL PLACEMENT OF ALL PEDESTRIAN PUSHBUTTONS SHALL BE IN ACCORDANCE WITH ADAAG AND THE MANUAL ON UNIFORM TRAFFIC CONTROL DEVICES, LATEST EDITION.
12. ALL LOOP DETECTORS SHALL BE CENTERED WITHIN EACH LANE AS DELINEATED, UNLESS OTHERWISE DIMENSIONED ON PLANS.
13. ALL LOOP DETECTORS SHALL BE CUT INTO THE FINAL PAVEMENT SURFACE COURSE.
14. TRAFFIC SIGNAL CONTROLLERS SHALL BE WIRED SO THAT ANY FIRE PRE-EMPTION SHALL OVERRIDE MANUAL (PUSH BUTTON) OPERATION.
15. THE CONTRACTOR SHALL WORK CONTINUOUSLY TO RESTORE TRAFFIC SIGNAL OPERATION TO ITS INTENDED PURPOSE WHEN REPLACING THE TRAFFIC SIGNAL EQUIPMENT. A POLICE DETAIL IS REQUIRED TO DIRECT TRAFFIC AT THE INTERSECTION AT ALL TIMES WHEN THE TRAFFIC SIGNAL IS INOPERATIVE. AT NO TIME SHALL THE CONTRACTOR LEAVE THE SITE BEFORE RESTORING FULL TRAFFIC OPERATIONS.

MAINTENANCE AND PROTECTION OF TRAFFIC NOTES:

1. ALL MAINTENANCE AND PROTECTION OF TRAFFIC CONTROL SETUPS, SIGNS, CHANNELIZING DEVICES, ETC., SHALL BE IN ACCORDANCE WITH THE MANUAL ON UNIFORM TRAFFIC CONTROL DEVICES, LATEST EDITION.
2. ALL SIGN MOUNTINGS FOR TEMPORARY AND CONSTRUCTION SIGNS SHALL BE IN ACCORDANCE WITH THE R.I.D.O.T. STANDARD SPECIFICATIONS, LATEST EDITION.
3. THE CONTRACTOR SHALL COVER ALL EXISTING AND/OR TEMPORARY SIGNS THAT ARE NOT RELEVANT TO THE TRAFFIC CONTROL REQUIRED DURING ANY PARTICULAR STAGE OF THE CONTRACT.
4. ADVANCE FLAGPERSON SIGNS (W20-7A) SHALL BE USED IN ADVANCE OF ANY POINT AT WHICH A FLAGPERSON OR A POLICE OFFICER HAS BEEN STATIONED TO CONTROL TRAFFIC. WHEN NEEDED, AN APPROPRIATE DISTANCE MESSAGE MAY BE DISPLAYED ON A SUPPLEMENTAL PLATE (24"x18") BELOW THE FLAGPERSON SYMBOL SIGN. THE SIGN SHALL BE PROMPTLY REMOVED OR COVERED WHENEVER THE FLAGPERSON IS NOT AT THE STATION.
5. POLICE OFFICERS (AND NOT FLAGPERSONS) SHALL BE UTILIZED WHEN WORK WILL IMPACT SIGNALIZED INTERSECTIONS AND LIMITED ACCESS HIGHWAYS.
6. POLYETHYLENE DRUMS SHALL BE UTILIZED AS A CHANNELIZING DEVICE WHEN A TRAFFIC CONTROL SET-UP IS TO REMAIN BEYOND WORKING HOURS WHEN NO WORKERS ARE PRESENT. CONES SHALL BE UTILIZED WHEN A TRAFFIC CONTROL SET-UP IS TO REMAIN ONLY DURING WORKING HOURS AND IS SUBSEQUENTLY BROKEN DOWN AT THE END OF THE WORKDAY.
7. ARROW PANELS SHALL BE SET IN THE FLASHING FOUR CORNERS CAUTION MODE UNLESS UTILIZED FOR A MERGING TAPER. ARROW PANELS SET IN THE FLASHING ARROW MODE SHALL NOT BE UTILIZED FOR LANE SHIFTS.
8. TEMPORARY CONSTRUCTION SIGNS AND OTHER WORKZONE TRAFFIC CONTROL DEVICES THAT ARE DAMAGED OR REQUIRE RELOCATION SHALL BE REPLACED AND / OR RELOCATED UNDER THE PAY ITEM FOR "MAINTENANCE AND MOVEMENT TRAFFIC PROTECTION."
9. THE PRIVATE VEHICLES OF CONSTRUCTION WORKERS SHALL NOT BE PARKED ON THE TRAVEL LANES OR SHOULDERS. THEY MAY BE PARKED WITHIN THE STATE RIGHT-OF-WAY ONLY IN AREAS 30' BEYOND THE OUTSIDE EDGE OF THE TRAVEL LANES AND/OR IN AREAS APPROVED BY THE ENGINEER.
10. TEMPORARY CONSTRUCTION SIGNS AND OTHER TEMPORARY TRAFFIC CONTROL DEVICES SHALL BE INSTALLED PRIOR TO THE START OF WORK IN ANY AREA OPEN TO TRAFFIC, AND SHALL BE REMOVED AS SOON AS PRACTICAL WHEN THEY ARE NO LONGER APPROPRIATE.
11. THE INTENDED VEHICLE PATHS THROUGH EACH WORK ZONE SHALL BE CLEARLY MARKED AT ALL TIMES. WATERBORNE PAVEMENT MARKINGS SHALL BE INSTALLED BEFORE THE END OF THE WORK SHIFT ON ALL COLD-PLANED AND NEW ROADWAY SURFACES THAT WILL BE OPENED TO TRAFFIC AT THE END OF THE SHIFT.

THIS PLAN SHALL NOT BE ALTERED

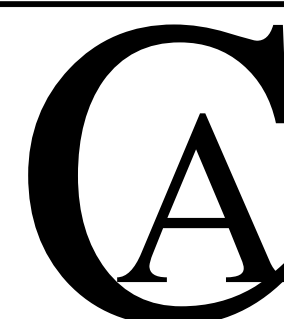

RA CATALDO & ASSOCIATES INC.
CIVIL ENGINEERS - LAND SURVEYORS

(401) 453-3300
FAX: (401) 453-4117
ca@cataldoeng.com

114 SMITHFIELD AVENUE
PAWTUCKET, RHODE ISLAND 02860



**CITY OF
CENTRAL FALLS**

DESIGNED BY:
CHECKED BY:
DATE:
SHEET: 3
OF: 21

SCALE: NO SCALE

REVISIONS			REVISIONS		
NO.	DATE	BY	NO.	DATE	BY
1	4/07	TRB			
2	3/10	RBH			

INFRASTRUCTURE AND STREETScape IMPROVEMENTS
SYLVIAN STREET
CENTRAL FALLS CONTRACT: 2021-0011 RHODE ISLAND

STANDARD NOTES 2

GENERAL NOTES:

- IT ALL WORK AND MATERIALS SHALL CONFORM TO THE R.I. STANDARD SPECIFICATIONS FOR ROAD AND BRIDGE CONSTRUCTION AMENDED MARCH 2018 WITH ALL REVISIONS AND ADDENDA AND THE R.I. STANDARD DETAILS, JUNE 21, 2019 EDITION WITH ALL REVISIONS AND THE CURRENT CITY OF CENTRAL FALLS REGULATIONS AND REQUIREMENTS.
- ALL TRAFFIC CONTROL SHALL CONFORM TO THE MANUAL ON UNIFORM TRAFFIC CONTROL DEVICES 2009, INCLUDING ALL REVISIONS.
- ALL WORK AND GRADING SHALL BE IN CONFORMANCE WITH THE 2010 AMERICANS WITH DISABILITIES ACT (ADA) STANDARDS FOR ACCESSIBILITY DESIGN, WITH THE LATEST REVISIONS.
- IT SHALL BE THE CONTRACTOR'S SOLE RESPONSIBILITY TO OBTAIN ANY AND ALL PERMITS REQUIRED BY THE STATE AND THE CITY IN WHICH WORK IS BEING PERFORMED PRIOR TO START OF ANY WORK.
- THE CONTRACTOR SHALL BE RESPONSIBLE FOR MAINTENANCE AND PROTECTION OF PEDESTRIAN AND VEHICULAR TRAFFIC INCLUDING POLICE PROTECTION. ALL TEMPORARY CONSTRUCTION SIGNS, BARRICADES AND LANE CLOSURES SHALL BE IN CONFORMANCE WITH THE LATEST "MANUAL OF UNIFORM TRAFFIC CONTROL DEVICES" (MUTCD).
- PRIOR TO COMMENCING ANY WORK, THE CONTRACTOR SHALL ERECT ALL SIGNS, BARRICADES AND OTHER DEVICES TO SECURE THE SITE AND CREATE A SAFE WORKING ENVIRONMENT, IN ACCORDANCE WITH THE MANUAL OF UNIFORM TRAFFIC CONTROL DEVICES (MUTCD) AND APPROVED TRAFFIC CONTROL PLANS. OPERATIONS SHALL BE CONDUCTED IN SUCH A MANNER AS TO CAUSE AS LITTLE INCONVENIENCE AS POSSIBLE TO ABUTTERS AND TRAFFIC. CONVENIENT ACCESS TO DRIVEWAYS, HOUSES AND BUILDING ALONG THE LINE OF THE WORK SHALL BE MAINTAINED WHENEVER POSSIBLE.
- IT SHALL BE THE CONTRACTORS SOLE RESPONSIBILITY TO DOCUMENT ALL EXISTING CONDITIONS OF THE WORK SITE INCLUDING SURROUNDING PROPERTIES AND TO MAINTAIN THE INTEGRITY OF THE SAME. ANY DAMAGE TO AND THE COST OF REPAIR OF DAMAGED PROPERTY, INCLUDING UTILITIES, ROADWAYS, STRUCTURES AND SURROUNDING PROPERTY SHALL BE FULLY BORNE BY THE CONTRACTOR.
- THE CONTRACTOR IS RESPONSIBLE FOR DETERMINING FINISHED GRADES AND ENSURING SURFACE WATER FLOWS TOWARDS SEDIMENTATION BARRIERS. ALL EXISTING PAVEMENT ELEVATIONS TO BE FIELD VERIFIED PRIOR TO PAVEMENT ACTIVITIES.
- THE CONTRACTOR SHALL CONTACT ALL UTILITY COMPANIES AND THE CITY PUBLIC WORKS DEPARTMENT FOR VERIFICATION OF APPROVED LOCATIONS SHOWN HEREON PRIOR TO START OF CONSTRUCTION. IF ANY DISCREPANCIES ARE NOTED, THE CONTRACTOR SHALL CONTACT THIS ENGINEER IMMEDIATELY FOR A RESOLUTION.
- IT SHALL BE THE CONTRACTOR'S RESPONSIBILITY TO COORDINATE, COOPERATE AND SCHEDULE IT'S WORK AND ALL SEGMENTS THEREOF WITH THE ENGINEER, OTHER CONTRACTORS, UTILITY OWNERS AND APPLICABLE LOCAL AUTHORITIES.
- THE CONTRACTOR SHALL ARRANGE AND COOPERATE WITH THE VARIOUS UTILITIES OR OTHER PARTIES INTERESTED WHEN NECESSARY AS DIRECTED BY THE ENGINEER. THE CONTRACTOR WILL BE RESPONSIBLE FOR ANY DAMAGE DONE TO ANY UTILITY POLES OR LINES, CURBING, BASINS, HYDRANTS, WATER AND SEWER LINES, CONDUITS AND OTHER ACCESSORIES AND APPURTENANCES. THE COST FOR COORDINATION SHALL BE INCIDENTAL TO THE WORK.
- THE CONTRACTOR SHALL OBTAIN THE REQUIRED INSPECTION SCHEDULE OF THE STATE, MUNICIPALITY, UTILITY COMPANIES AND ALL OTHER REQUIRED PARTIES AND SHALL STRICTLY ADHERE TO THOSE REQUIREMENTS.
- THE CONTRACTOR IS RESPONSIBLE FOR ALL SOIL EROSION AND SEDIMENT CONTROL MEASURES ONSITE.
- THE CONTRACTOR SHALL CLEAN UP THE WORK AREA AT THE END OF EACH WORK DAY. THE CONTRACTOR SHALL NOT STOCKPILE ANY MATERIAL IN THE PUBLIC RIGHT-OF-WAY (ROW) WITHOUT PERMISSION FROM THE CITY.
- CONTRACTOR TO PERFORM DAILY HOUSEKEEPING ONSITE. CONTRACTOR SHALL SWEEP DAILY ANY TRACKING ONTO A SUITABLE AREA TO PREVENT FROM ENTERING THE DRAINAGE SYSTEM.

- THE PROPOSED SIDEWALK LIMITS SHALL BE ADJUSTED SO THAT THE ENTIRE SIDEWALK SQUARE OF CONCRETE IS REPLACED IN ACCORDANCE WITH RI STD 43.1.0. NO PATCHES WILL BE ALLOWED.
- ALL EXISTING UTILITIES ARE FROM VISIBLE INFORMATION, DRAWINGS FROM OTHERS, OR INFORMATION PROVIDED. ALL ELEVATIONS AND LOCATIONS ARE APPROXIMATE ONLY AND SHOULD BE FIELD VERIFIED BY THE CONTRACTOR AND DIGSAFE. THE CONTRACTOR SHALL COORDINATE ALL UTILITIES WITH THE APPROPRIATE UTILITY COMPANIES.
- THE CONTRACTOR SHALL CONTACT ALL UTILITY COMPANIES IN ADDITION TO CONTACTING DIG SAFE AT 811 OR 888-DIG-SAFE (888-344-7233) AT LEAST 72 BUSINESS HOURS (3 BUSINESS DAYS) PRIOR TO ANY EXCAVATION AS DEFINED BY RI STATE LAW 39-1.2-1. THIS DOES NOT INCLUDE WEEKENDS AND LEGAL HOLIDAYS. ONCE NOTIFIED, DIG SAFE WILL CONTACT MEMBER UTILITIES TO COME TO THE SITE AND MARK UNDERGROUND UTILITY WIRES, CABLES AND PIPELINES.
- DIG SAFE MEMBER UTILITY COMPANIES ARE RESPONSIBLE TO MARK ONLY THE FACILITIES THAT THEY OWN OR MAINTAIN. NON DIG SAFE MEMBER COMPANIES ARE NOT NOTIFIED BY DIG SAFE. NON-MEMBER UTILITIES MAY NOT BE OWNED OR MAINTAINED BY MEMBER UTILITY COMPANIES; THEREFORE THEY ARE UNABLE TO LOCATE THEM. IT IS YOUR RESPONSIBILITY TO INVESTIGATE IF ANY PRIVATELY OWNED OR NON DIG SAFE MEMBER UTILITIES ARE IN THE AREA.
- WORK SHALL BE PERFORMED DURING NORMAL BUSINESS HOURS, MONDAY THROUGH FRIDAY, 7:00 AM-5:00PM. SOME JOBS MAY REQUIRE THE CONTRACTOR TO WORK OUTSIDE NORMAL BUSINESS HOURS. IN THIS EVENT, WORK CONDITIONS WILL BE MADE CLEAR TO THE CONTRACTOR PRIOR TO AWARDED THE WORK. ALSO, THE CONTRACTOR MAY REQUEST TO WORK ON SATURDAYS AND SUNDAY OR OUTSIDE OF NORMAL BUSINESS HOURS, ONLY WITH APPROVAL FROM THE CITY.
- THE CONTRACTOR SHALL PROVIDE NOTICE TO ABUTTERS AT LEAST 24 HOURS BEFORE SIDEWALK OR DRIVEWAY WORK WILL BE PERFORMED. WHEN INSTALLING CEMENT CONCRETE DRIVEWAYS, THE CONTRACTOR SHALL PROVIDE AT LEAST 48 HOURS NOTICE THAT THE DRIVEWAY WILL BE INACCESSIBLE WHILE GRADING, FORMING, POURING AND CURING. THE NOTICES SHALL STATE THE CONTRACTOR'S NAME, INCLUDE A STATEMENT THAT THE CONTRACTOR IS WORKING FOR THE CITY OF CENTRAL FALLS, A CONTACT NAME AND PHONE NUMBER FOR THE CONTRACTOR AND THE DATE AND TIME THAT THE DRIVEWAY WILL BE ACCESSIBLE. THE CONTRACTOR SHALL REMOVE ALL WARNING TAPE AND STAKES WHEN THE DRIVEWAY IS ACCESSIBLE. THE CONTRACTOR SHALL ALSO COORDINATE WITH THE CITY'S PARKING ADMINISTRATOR WHEN RESIDENTS ARE DISPLACED DURING A DRIVEWAY POUR. THE PARKING ADMINISTRATOR WILL COORDINATE WITH THE CENTRAL FALLS POLICE DEPARTMENT TO ALLOW FOR OVERNIGHT STREET PARKING.

LEGEND	
EXISTING	PROPOSED

RA CATALDO & ASSOCIATES INC.
 CIVIL ENGINEERS - LAND SURVEYORS
 (401) 453-3300
 FAX: (401) 453-4117
 ca@cataldoeng.com
 114 SMITHFIELD AVENUE
 PAWTUCKET, RHODE ISLAND 02860



CITY OF
 CENTRAL FALLS

DESIGNED BY:
 CHECKED BY:
 DATE: 08/20/2021
 SHEET: 4
 OF: 21

SCALE: NO SCALE

REVISIONS			REVISIONS		
NO.	DATE	BY	NO.	DATE	BY

INFRASTRUCTURE AND STREETScape IMPROVEMENTS
SYLVIAN STREET
 CENTRAL FALLS CONTRACT: 2021-0011 RHODE ISLAND
JOB SPECIFIC NOTES & LEGEND

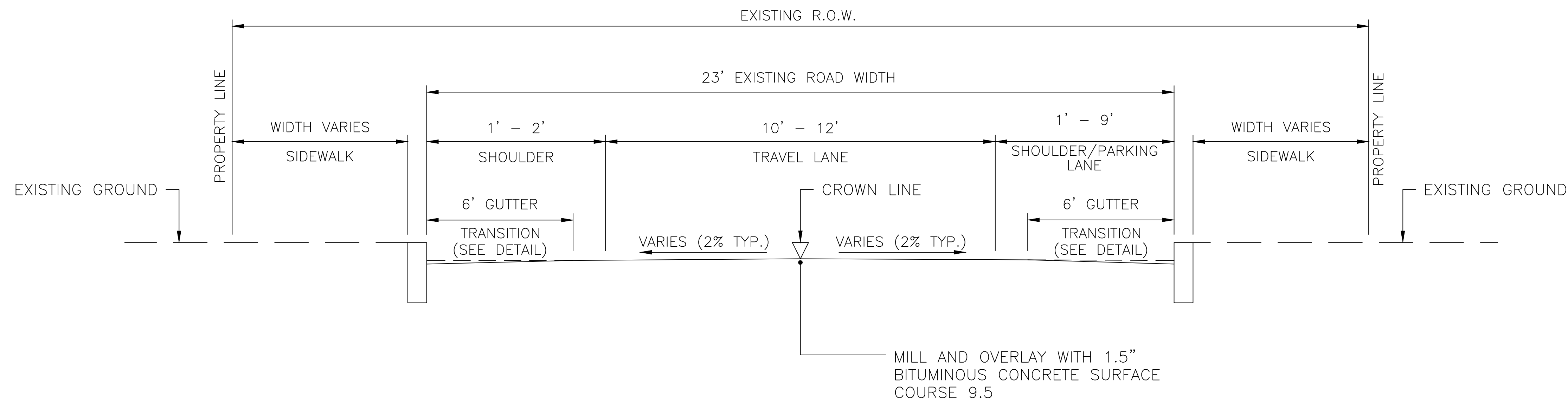

NOTE:
TACK COAT ALL MILLED SURFACES
PRIOR TO PLACING NEW PAVEMENT

**SYLVIAN STREET TYPICAL SECTION
MILL AND OVERLAY WITH GUTTER TRANSITION**

NOT TO SCALE

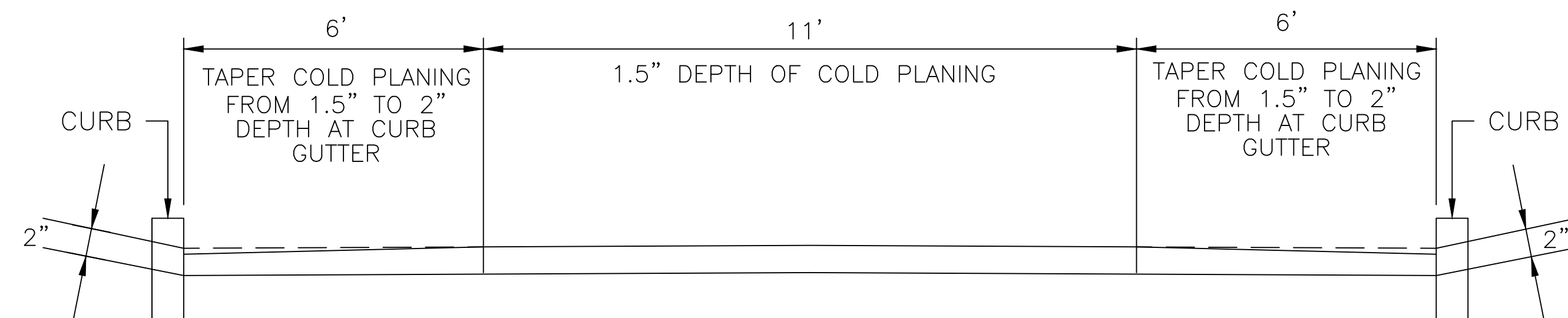

NOTE:
TYPICAL 1.5"-2" COLD PLANING TO PROVIDE 0.5"
OF ADDITIONAL CURB REVEAL. OVERLAY WITH 1.5"
BITUMINOUS CONCRETE SURFACE COURSE 9.5

GUTTER TRANSITION DETAIL

NOT TO SCALE

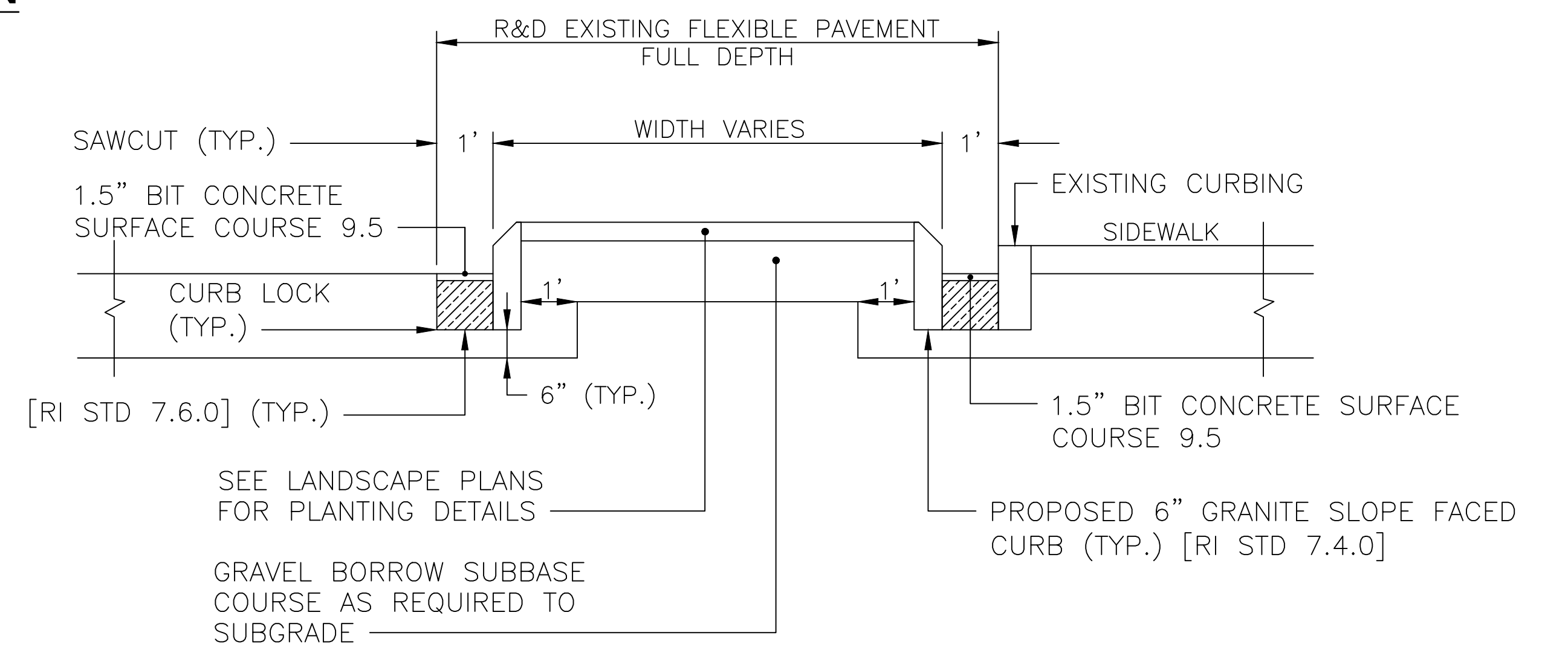

NOTE:
SAWCUT 1' ALL AROUND PROPOSED ISLANDS. R&D
EXISTING FLEXIBLE PAVEMENT FULL DEPTH (TYP.)

TYPICAL CHICANE SECTION DETAIL

NOT TO SCALE

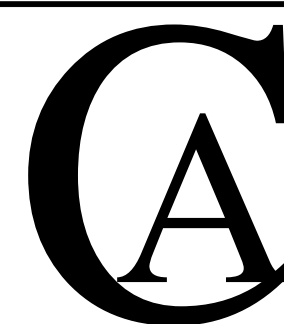

RA CATALDO & ASSOCIATES INC.
CIVIL ENGINEERS - LAND SURVEYORS

(401) 453-3300
FAX: (401) 453-4117
ca@cataldoeng.com

114 SMITHFIELD AVENUE
PAWTUCKET, RHODE ISLAND 02860



CITY OF
CENTRAL FALLS

DESIGNED BY: RAC/CD
CHECKED BY: RWC
DATE: 08/20/2021
SHEET: 5
OF: 21

SCALE: AS SHOWN

REVISIONS			REVISIONS		
NO.	DATE	BY	NO.	DATE	BY

INFRASTRUCTURE AND STREETScape IMPROVEMENTS
SYLVIAN STREET
CENTRAL FALLS, RHODE ISLAND
CONTRACT: 2021-0011

TYPICAL SECTIONS

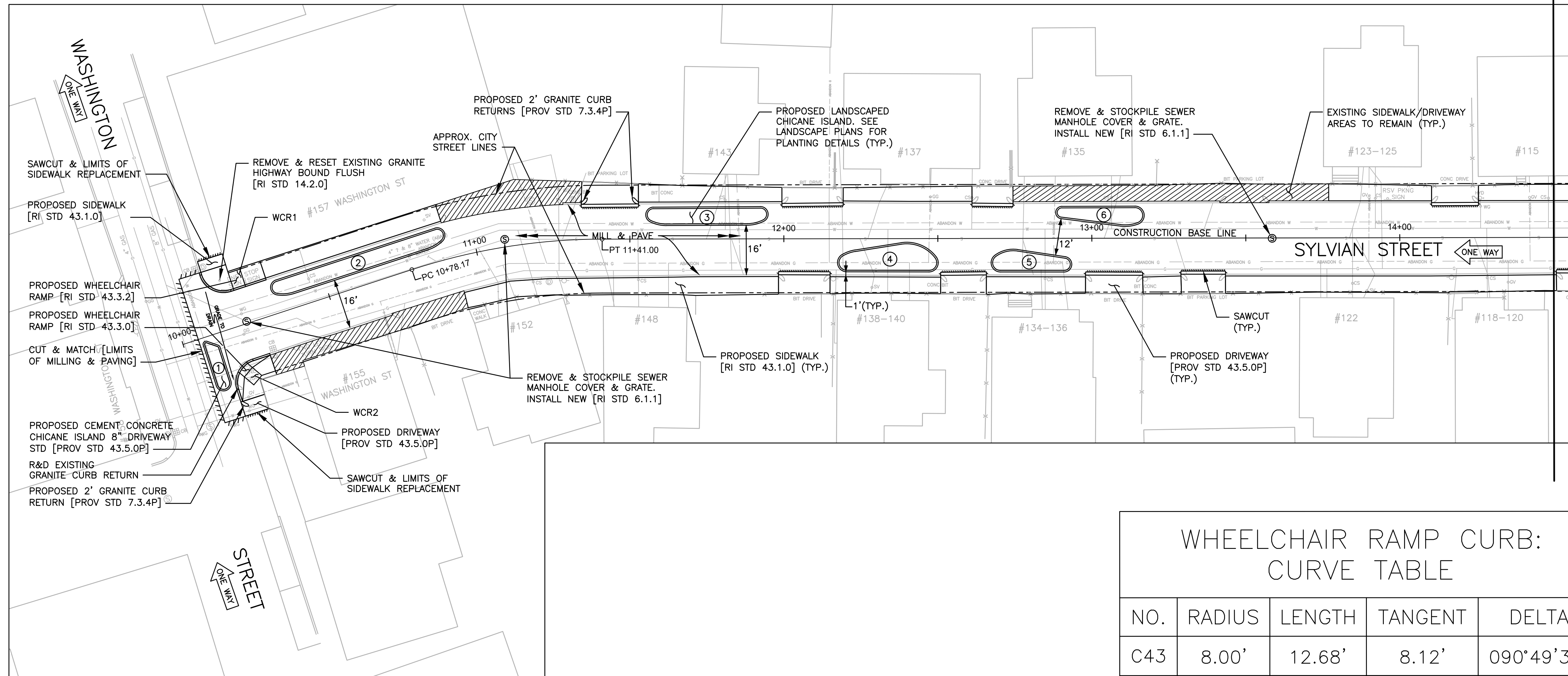

MATCHLINE GENERAL PLAN NO. 2

WHEELCHAIR RAMP CURB:
CURVE TABLE

NO.	RADIUS	LENGTH	TANGENT	DELTA
C43	8.00'	12.68'	8.12'	090°49'38"
C44	8.00'	5.92'	3.10'	042°22'13"
C45	8.00'	4.37'	2.24'	031°17'18"
C46	8.00'	2.18'	1.10'	015°38'30"

WHEELCHAIR RAMP CURB:
LINE TABLE

NO.	LENGTH
L29	0.80'
L30	0.97'
L31	4.00'
L32	7.00'
L33	4.09'
L34	5.82'

- NOTES:
- ALL PROPOSED ISLANDS SHALL HAVE 6" GRANITE SLOPE FACED CURB. [RI STD 7.4.0]
 - ALL SURFACE UTILITIES WITHIN THE LIMITS OF THE RESURFACING AND SIDEWALK/DRIVEWAY AREAS DESIGNATED FOR REPLACEMENT SHALL BE ADJUSTED TO GRADE AS REQUIRED.
 - REPLACE ALL SIDEWALKS AND DRIVEWAYS WITHIN THE LIMITS OF RESURFACING UNLESS DESIGNATED TO REMAIN.

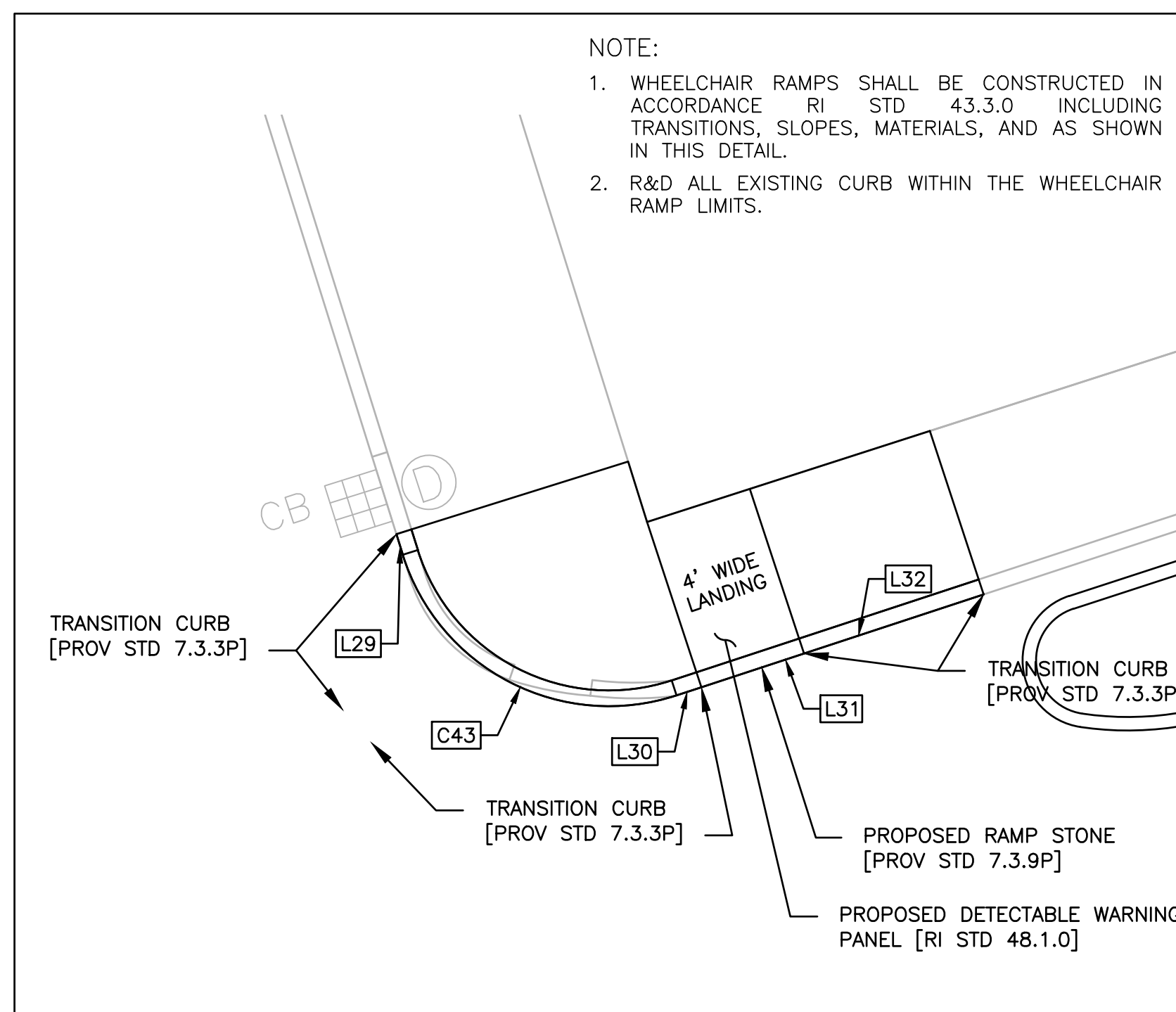

WHEELCHAIR RAMP DETAIL - WCR1

SCALE: 1" = 5'

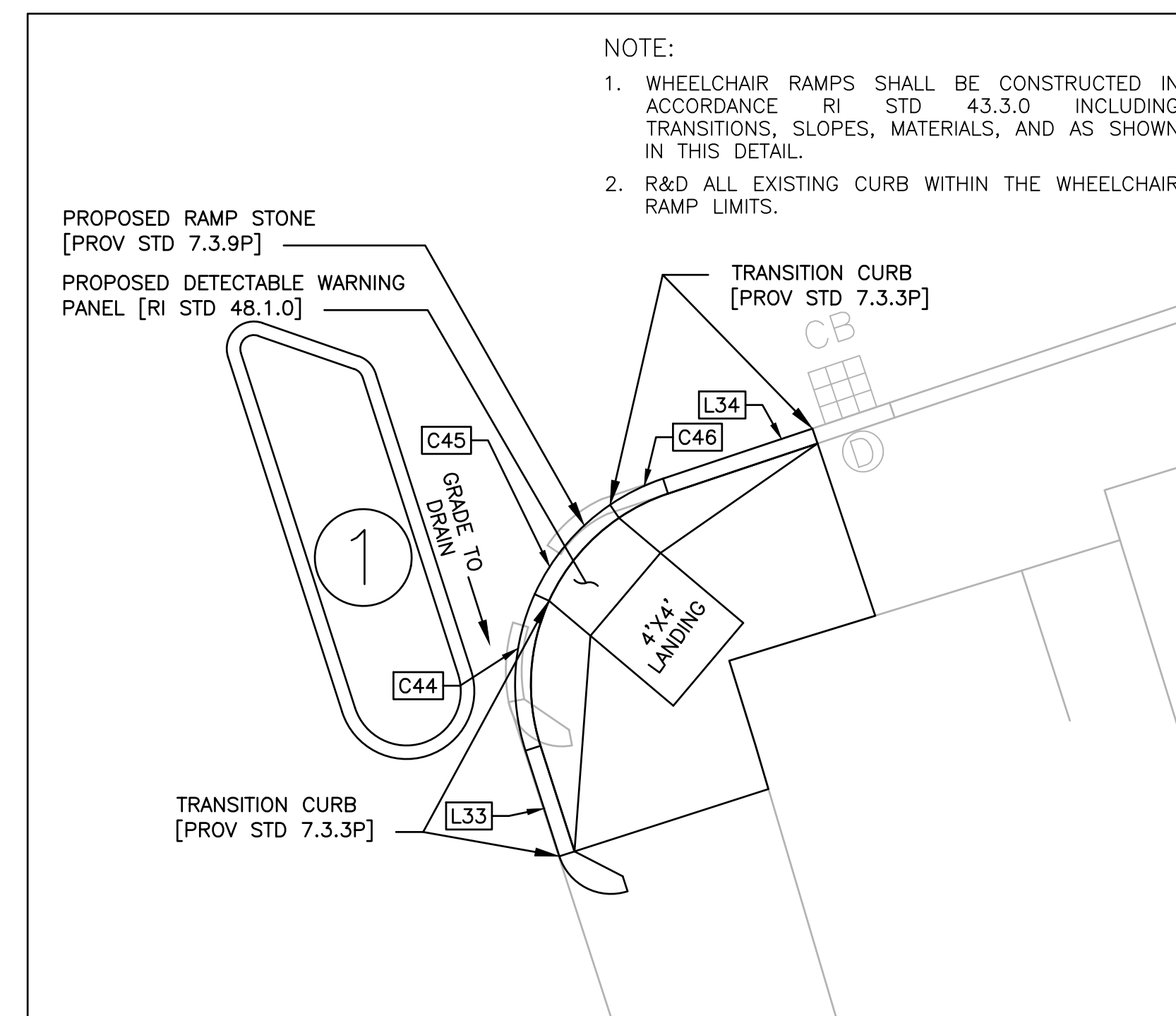

WHEELCHAIR RAMP DETAIL - WCR2

SCALE: 1" = 5'

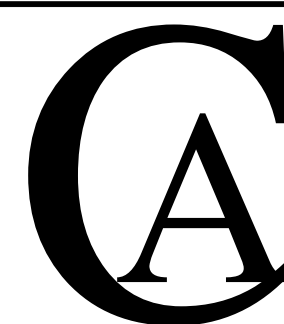

RA CATALDO & ASSOCIATES INC.
CIVIL ENGINEERS - LAND SURVEYORS

(401) 453-3300
FAX: (401) 453-4117
ca@cataldoeng.com

114 SMITHFIELD AVENUE
PAWTUCKET, RHODE ISLAND 02860



CITY OF
CENTRAL FALLS

DESIGNED BY: JJP/RAC
CHECKED BY: RWC
DATE: 08/20/2021
SHEET: 6
OF: 21

SCALE: 1"=20'

REVISIONS			REVISIONS		
NO.	DATE	BY	NO.	DATE	BY

INFRASTRUCTURE AND STREETSCAPE IMPROVEMENTS
SYLVIAN STREET
CENTRAL FALLS, RHODE ISLAND
CONTRACT: 2021-0011

GENERAL PLAN NO. 1

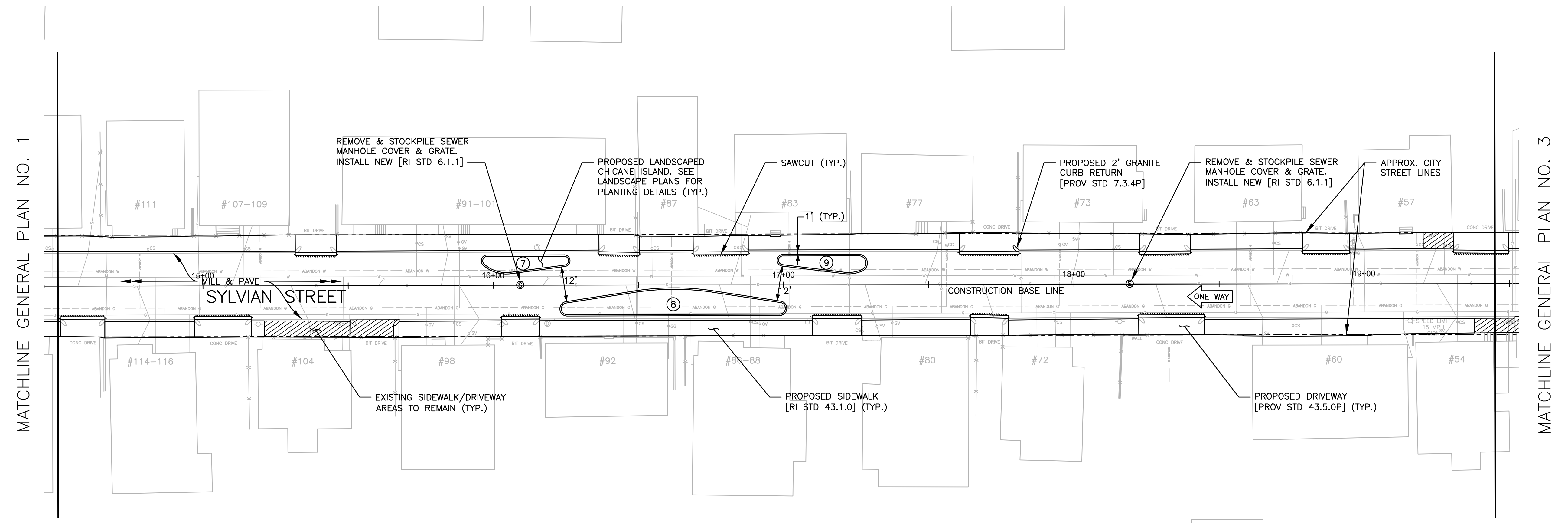

- NOTES:
1. ALL PROPOSED ISLANDS SHALL HAVE 6" GRANITE SLOPE FACED CURB. [RI STD 7.4.0]
 2. ALL SURFACE UTILITIES WITHIN THE LIMITS OF THE RESURFACING AND SIDEWALK/DRIVEWAY AREAS DESIGNATED FOR REPLACEMENT SHALL BE ADJUSTED TO GRADE AS REQUIRED.
 3. REPLACE ALL SIDEWALKS AND DRIVEWAYS WITHIN THE LIMITS OF RESURFACING UNLESS DESIGNATED TO REMAIN.

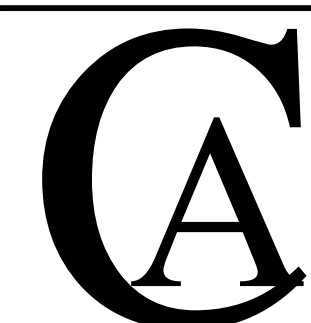

RA CATALDO & ASSOCIATES INC.
 CIVIL ENGINEERS - LAND SURVEYORS
 (401) 453-3300
 FAX: (401) 453-4117
 ca@cataldoeng.com
 114 SMITHFIELD AVENUE
 PAWTUCKET, RHODE ISLAND 02860



CITY OF
CENTRAL FALLS

DESIGNED BY: JJP/RAC
 CHECKED BY: RWC
 DATE: 08/20/2021
 SHEET: 7
 OF: 21

SCALE: 1"=20'

REVISIONS			REVISIONS		
NO.	DATE	BY	NO.	DATE	BY

INFRASTRUCTURE AND STREETSCAPE IMPROVEMENTS
SYLVIAN STREET
 CONTRACT: 2021-0011
 CENTRAL FALLS, RHODE ISLAND
GENERAL PLAN NO. 2

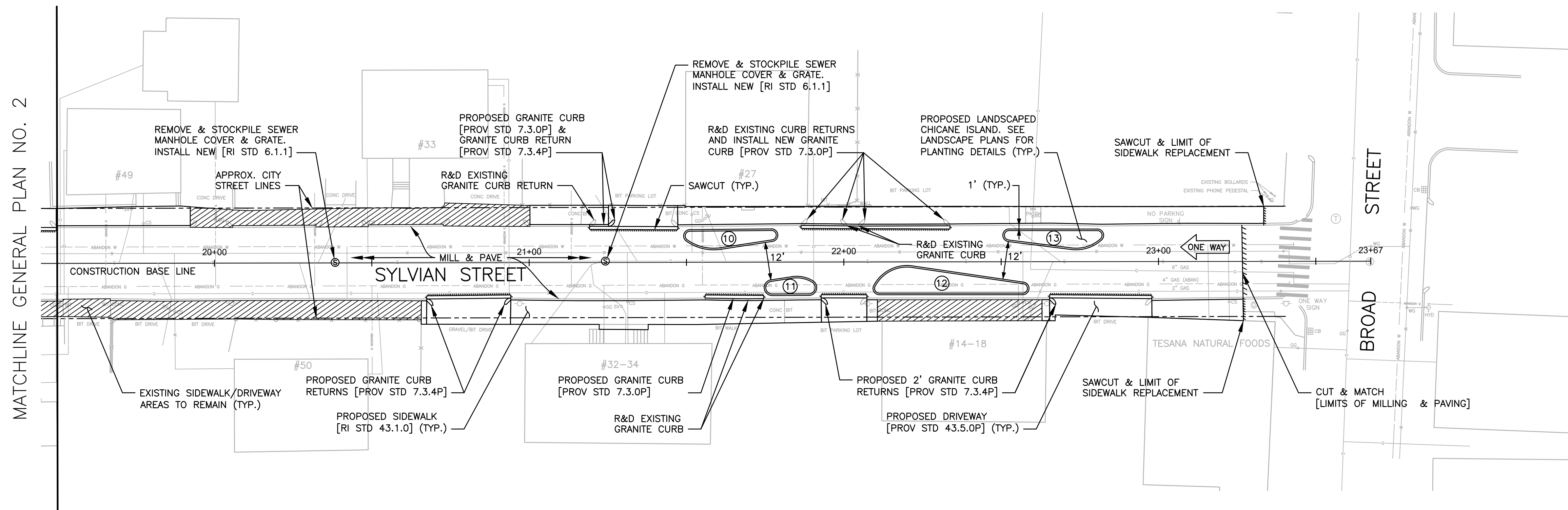

MATCHLINE GENERAL PLAN NO. 2

- NOTES:
1. ALL PROPOSED ISLANDS SHALL HAVE 6" GRANITE SLOPE FACED CURB. [RI STD 7.4.0]
 2. ALL SURFACE UTILITIES WITHIN THE LIMITS OF THE RESURFACING AND SIDEWALK/DRIVEWAY AREAS DESIGNATED FOR REPLACEMENT SHALL BE ADJUSTED TO GRADE AS REQUIRED.
 3. REPLACE ALL SIDEWALKS AND DRIVEWAYS WITHIN THE LIMITS OF RESURFACING UNLESS DESIGNATED TO REMAIN.

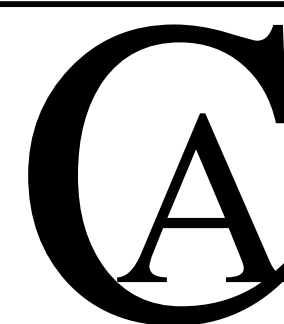

RA CATALDO & ASSOCIATES INC.
CIVIL ENGINEERS - LAND SURVEYORS

(401) 453-3300
FAX: (401) 453-4117
ca@cataldoeng.com

114 SMITHFIELD AVENUE
PAWTUCKET, RHODE ISLAND 02860



CITY OF
CENTRAL FALLS

DESIGNED BY: JJP/RAC
CHECKED BY: RWC
DATE: 08/20/2021
SHEET: 8
OF: 21

SCALE: 1"=20'

REVISIONS			REVISIONS		
NO.	DATE	BY	NO.	DATE	BY

INFRASTRUCTURE AND STREETSCAPE IMPROVEMENTS
SYLVIAN STREET
CENTRAL FALLS CONTRACT: 2021-0011 RHODE ISLAND

GENERAL PLAN NO. 3

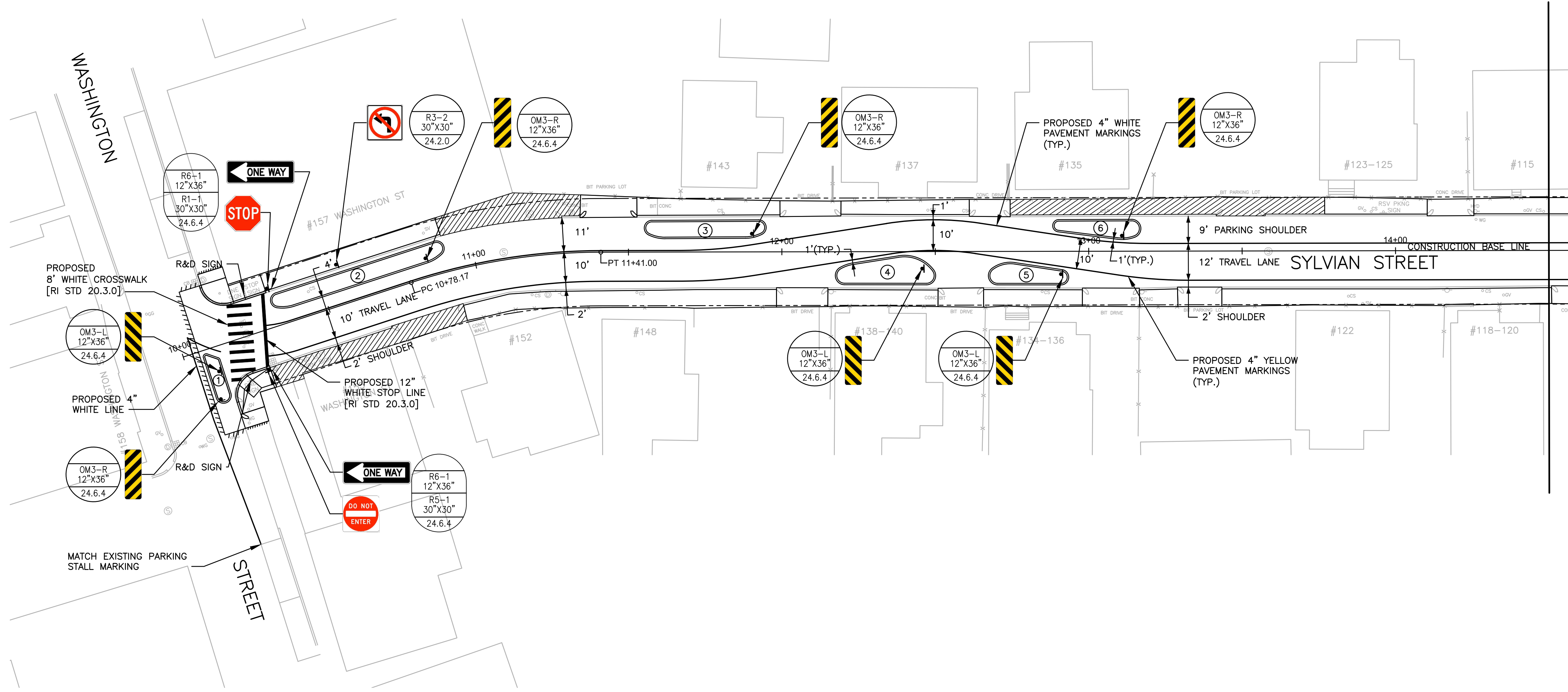

MATCHLINE SIGNING AND STRIPING PLAN NO. 2

NOTE:
 1. ALL PERMANENT PAVEMENT MARKINGS ARE REFLECTORIZED EPOXY PAVEMENT MARKINGS.

RA CATALDO & ASSOCIATES INC.
 CIVIL ENGINEERS - LAND SURVEYORS
 (401) 453-3300
 FAX: (401) 453-4117
 cc@cataldoeng.com
 114 SMITHFIELD AVENUE
 PAWTUCKET, RHODE ISLAND 02860



CITY OF
 CENTRAL FALLS

DESIGNED BY: RAC/CD
 CHECKED BY: RWC
 DATE: 08/20/2021
 SHEET: 9
 OF: 21

SCALE: 1"=20'

REVISIONS			REVISIONS		
NO.	DATE	BY	NO.	DATE	BY

INFRASTRUCTURE AND STREETSCAPE IMPROVEMENTS
SYLVIAN STREET
 CENTRAL FALLS CONTRACT: 2021-0011 RHODE ISLAND
SIGNING AND STRIPING PLAN NO. 1



MATCHLINE SIGNING AND STRIPING PLAN NO. 1

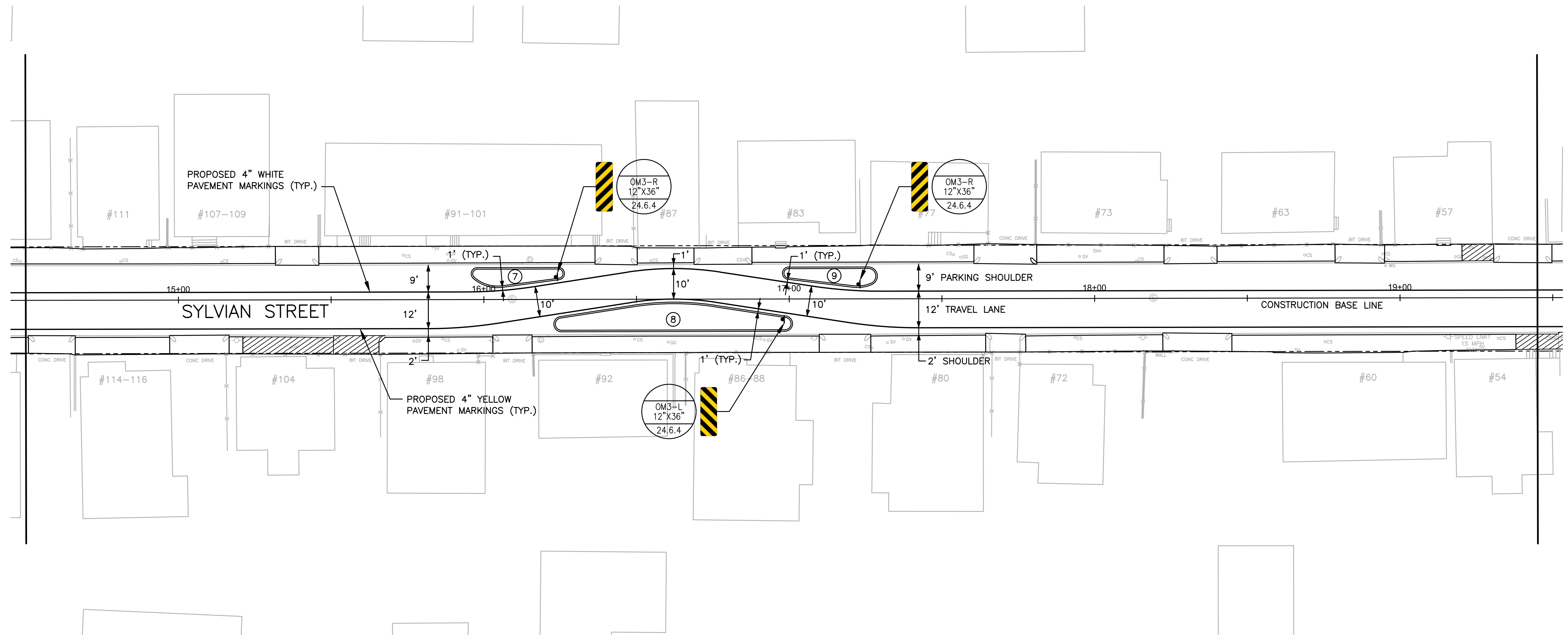

MATCHLINE SIGNING AND STRIPING PLAN NO. 3

NOTE:
 1. ALL PERMANENT PAVEMENT MARKINGS ARE REFLECTORIZED EPOXY PAVEMENT MARKINGS.

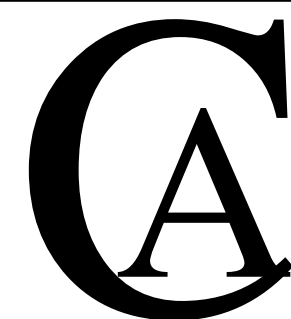

RA CATALDO & ASSOCIATES INC.
 CIVIL ENGINEERS - LAND SURVEYORS

(401) 453-3300
 FAX: (401) 453-4117
 ca@cataldoeng.com

114 SMITHFIELD AVENUE
 PAWTUCKET, RHODE ISLAND 02860



CITY OF
CENTRAL FALLS

DESIGNED BY: RAC/CD
 CHECKED BY: RWC
 DATE: 08/20/2021
 SHEET: 10
 OF: 21

SCALE: 1"=20'

REVISIONS			REVISIONS		
NO.	DATE	BY	NO.	DATE	BY

INFRASTRUCTURE AND STREETScape IMPROVEMENTS
SYLVIAN STREET

CENTRAL FALLS CONTRACT: 2021-0011 RHODE ISLAND

SIGNING AND STRIPING PLAN NO. 2



MATCHLINE SIGNING AND STRIPING PLAN NO. 2

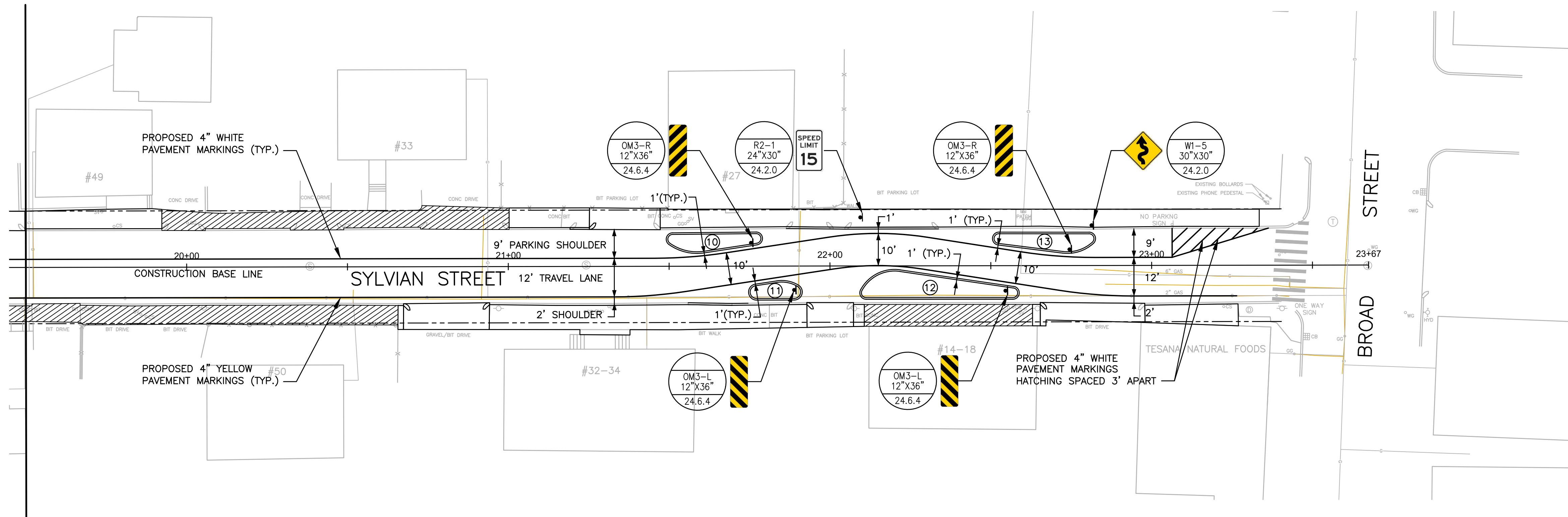

NOTE:
 1. ALL PERMANENT PAVEMENT MARKINGS ARE REFLECTORIZED EPOXY PAVEMENT MARKINGS.

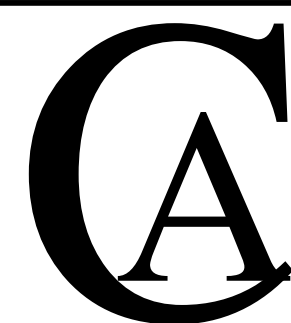

RA CATALDO & ASSOCIATES INC.
 CIVIL ENGINEERS - LAND SURVEYORS
 (401) 453-3300
 FAX: (401) 453-4117
 ca@cataldoeng.com
 114 SMITHFIELD AVENUE
 PAWTUCKET, RHODE ISLAND 02860



**CITY OF
 CENTRAL FALLS**

DESIGNED BY: RAC/CD
 CHECKED BY: RWC
 DATE: 08/20/2021
 SHEET: 11
 OF: 21

SCALE: 1"=20'

REVISIONS			REVISIONS		
NO.	DATE	BY	NO.	DATE	BY

INFRASTRUCTURE AND STREETScape IMPROVEMENTS
SYLVIAN STREET
 CENTRAL FALLS CONTRACT: 2021-0011 RHODE ISLAND
SIGNING AND STRIPING PLAN NO. 3

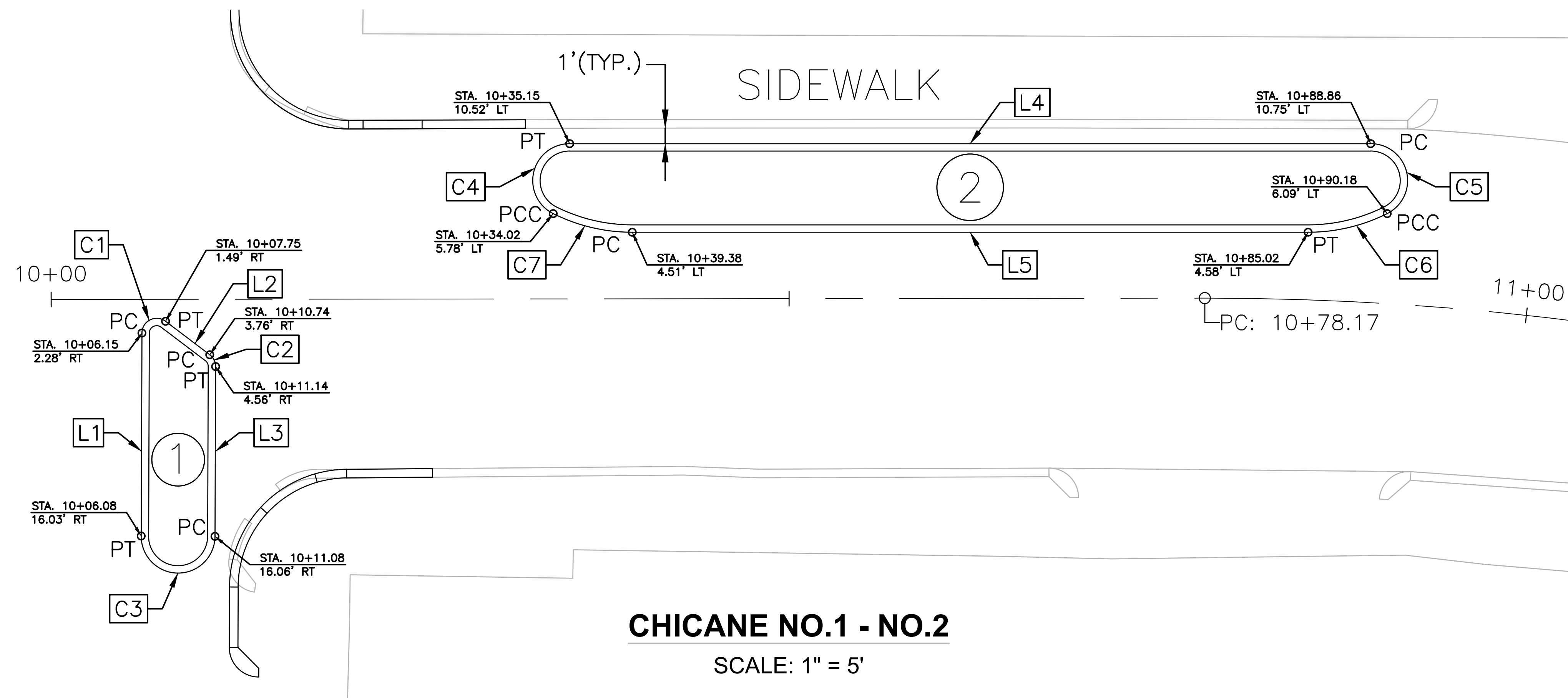

CHICANE NO.1 - NO.2

SCALE: 1" = 5'

CHICANE AREAS	*INTERIOR AREA [SQ FT]	**EXTERIOR AREA [SQ FT]
CHICANE 1	59.06	121.42
CHICANE 2	281.83	471.06

* INTERIOR AREA OF CHICANES, AREA DOES NOT INCLUDE THE CURBING.
 ** EXTERIOR AREA INCLUDES 1' FROM THE OUTSIDE FACE OF THE CURB AND INCLUDES THE INTERIOR AREA AND THE CURBING.

CHICANE: CURVE TABLE				
NO.	RADIUS	LENGTH	TANGENT	DELTA
C1	1.00'	2.22'	2.00'	126°54'39"
C2	1.00'	0.93'	0.50'	053°05'21"
C3	2.50'	7.85'	INFINITY'	180°00'00"
C4	2.50'	6.70'	10.61'	153°28'29"
C5	2.50'	6.70'	10.61'	153°28'29"
C6	12.00'	5.56'	2.83'	026°31'31"
C7	12.00'	5.56'	2.83'	026°31'31"

CHICANE: LINE TABLE	
NO.	LENGTH
L1	13.75'
L2	3.75'
L3	11.50'
L4	54.28'
L5	45.80'

NOTE:
 ALL PROPOSED CHICANE ISLANDS SHALL HAVE 6" GRANITE SLOPE FACED CURB. [RI STD 7.4.0]

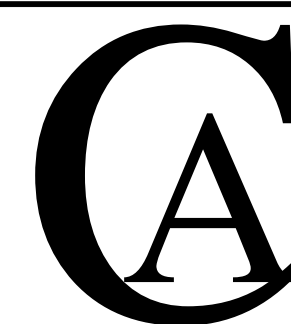

RA CATALDO & ASSOCIATES INC.
 CIVIL ENGINEERS - LAND SURVEYORS

(401) 453-3300
 FAX: (401) 453-4117
 ca@cataldoeng.com

114 SMITHFIELD AVENUE
 PAWTUCKET, RHODE ISLAND 02860



CITY OF
CENTRAL FALLS

DESIGNED BY: RAC/CD
 CHECKED BY: RWC
 DATE: 08/20/2021
 SHEET: 12
 OF: 21

SCALE: 1"=5'

REVISIONS			REVISIONS		
NO.	DATE	BY	NO.	DATE	BY

INFRASTRUCTURE AND STREETScape IMPROVEMENTS
SYLVIAN STREET
 CONTRACT: 2021-0011
 CENTRAL FALLS, RHODE ISLAND

CHICANE DETAILS 1

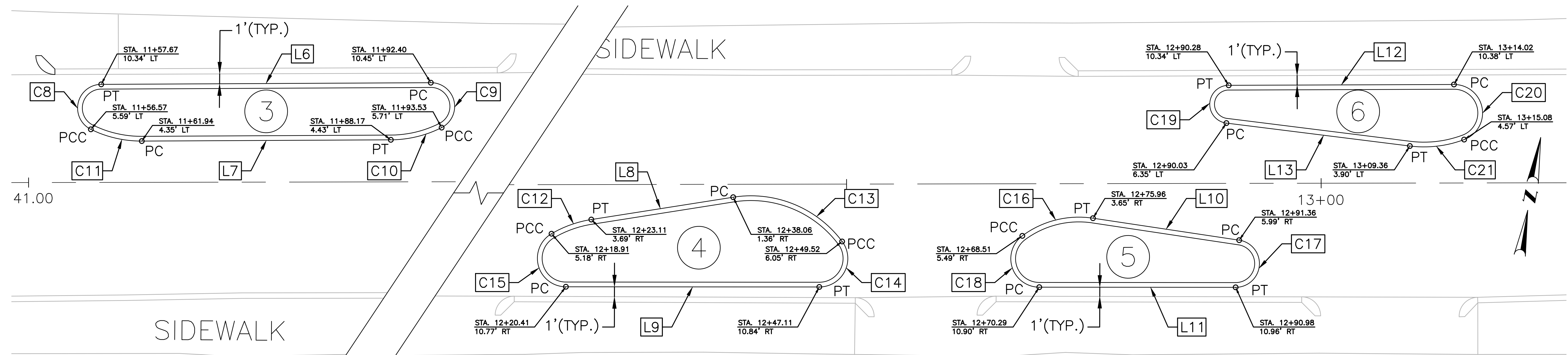

CHICANE NO.3 - NO.6

SCALE: 1" = 5'

CHICANE AREAS	*INTERIOR AREA [SQ FT]	**EXTERIOR AREA [SQ FT]
CHICANE 3	184.03	314.58
CHICANE 4	216.81	329.87
CHICANE 5	128.39	219.44
CHICANE 6	119.68	217.15

* INTERIOR AREA OF CHICANES, AREA DOES NOT INCLUDE THE CURBING.
 ** EXTERIOR AREA INCLUDES 1' FROM THE OUTSIDE FACE OF THE CURB AND INCLUDES THE INTERIOR AREA AND THE CURBING.

CHICANE: CURVE TABLE				
NO.	RADIUS	LENGTH	TANGENT	DELTA
C8	2.50'	6.70'	10.61'	153°28'29"
C9	2.50'	6.70'	10.61'	153°28'29"
C10	12.00'	5.56'	2.83'	026°31'31"
C11	12.00'	5.56'	2.83'	026°31'31"
C12	12.00'	4.48'	2.27'	021°23'22"
C13	12.00'	13.02'	7.23'	062°09'36"
C14	3.00'	6.64'	6.00'	126°50'27"
C15	3.00'	7.83'	11.05'	149°36'35"
C16	10.00'	7.87'	4.15'	045°07'08"
C17	2.50'	7.48'	33.68'	171°30'31"
C18	3.00'	7.51'	9.06'	143°22'21"
C19	2.00'	6.03'	31.23'	172°40'21"
C20	3.00'	8.36'	16.65'	159°34'24"
C21	12.00'	5.81'	2.96'	027°45'15"

CHICANE: LINE TABLE	
NO.	LENGTH
L6	34.72'
L7	26.24'
L8	15.13'
L9	26.70'
L10	15.58'
L11	20.69'
L12	23.74'
L13	19.48'

NOTE:
 ALL PROPOSED CHICANE ISLANDS SHALL HAVE 6" GRANITE SLOPE FACED CURB. [RI STD 7.4.0]

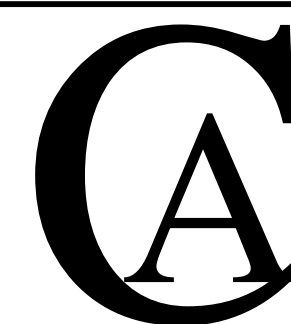

RA CATALDO & ASSOCIATES INC.
 CIVIL ENGINEERS - LAND SURVEYORS

(401) 453-3300
 FAX: (401) 453-4117
 ca@cataldoeng.com

114 SMITHFIELD AVENUE
 PAWTUCKET, RHODE ISLAND 02860



CITY OF
CENTRAL FALLS

DESIGNED BY: RAC/CD
 CHECKED BY: RWC
 DATE: 08/20/2021
 SHEET: 13
 OF: 21

SCALE: 1"=5'

REVISIONS				REVISIONS			
NO.	DATE	BY	NO.	DATE	BY	NO.	BY

INFRASTRUCTURE AND STREETSCAPE IMPROVEMENTS
SYLVIAN STREET
 CONTRACT: 2021-0011
 CENTRAL FALLS, RHODE ISLAND

CHICANE DETAILS 2

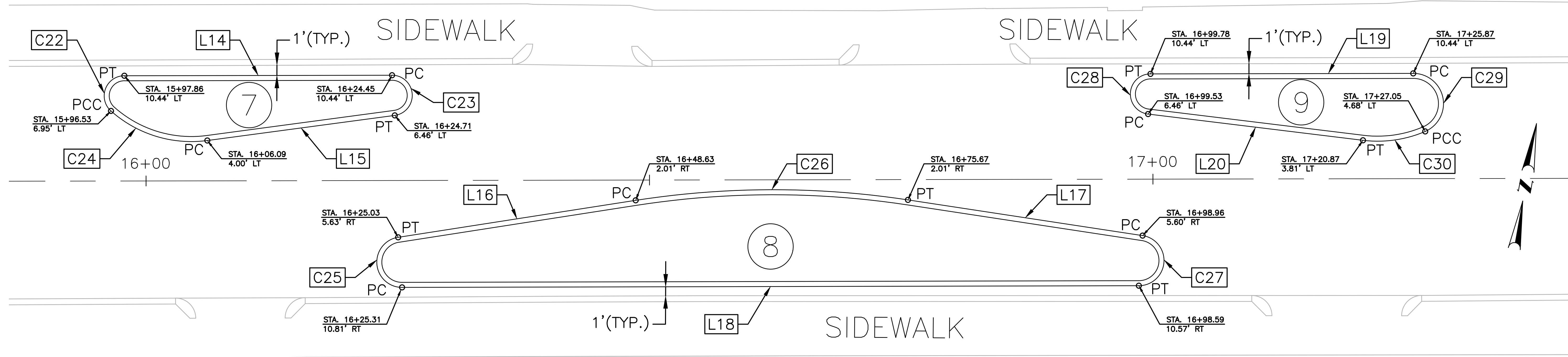

CHICANE NO.7 - NO.9

SCALE: 1" = 5'

CHICANE AREAS	*INTERIOR AREA [SQ FT]	**EXTERIOR AREA [SQ FT]
CHICANE 7	125.80	227.97
CHICANE 8	503.42	749.85
CHICANE 9	132.41	237.01

* INTERIOR AREA OF CHICANES, AREA DOES NOT INCLUDE THE CURBING.
 ** EXTERIOR AREA INCLUDES 1' FROM THE OUTSIDE FACE OF THE CURB AND INCLUDES THE INTERIOR AREA AND THE CURBING.

CHICANE: CURVE TABLE				
NO.	RADIUS	LENGTH	TANGENT	DELTA
C22	2.00'	4.82'	5.24'	138°13'25"
C23	2.00'	6.02'	30.45'	172°29'03"
C24	12.00'	10.32'	5.51'	049°17'32"
C25	2.50'	7.47'	32.86'	171°17'53"
C26	89.00'	27.15'	13.68'	017°28'35"
C27	2.50'	7.47'	32.58'	171°13'32"
C28	2.00'	6.04'	32.41'	172°56'15"
C29	3.00'	8.22'	14.70'	156°55'52"
C30	12.00'	6.31'	3.23'	030°07'53"

CHICANE: LINE TABLE	
NO.	LENGTH
L14	26.59'
L15	18.78'
L16	23.88'
L17	23.57'
L18	73.18'
L19	26.10'
L20	21.50'

NOTE:
 ALL PROPOSED CHICANE ISLANDS SHALL HAVE 6" GRANITE SLOPE FACED CURB. [RI STD 7.4.0]

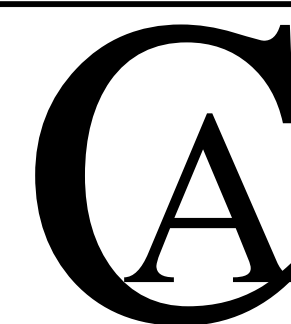

RA CATALDO & ASSOCIATES INC.
 CIVIL ENGINEERS - LAND SURVEYORS

(401) 453-3300
 FAX: (401) 453-4117
 ca@cataldoeng.com

114 SMITHFIELD AVENUE
 PAWTUCKET, RHODE ISLAND 02860



CITY OF
CENTRAL FALLS

DESIGNED BY: RAC/CD
 CHECKED BY: RWC
 DATE: 08/20/2021
 SHEET: 14
 OF: 21

SCALE: 1"=5'

REVISIONS				REVISIONS			
NO.	DATE	BY	NO.	DATE	BY	NO.	DATE

INFRASTRUCTURE AND STREETSCAPE IMPROVEMENTS
SYLVIAN STREET
 CENTRAL FALLS, RHODE ISLAND
 CONTRACT: 2021-0011

CHICANE DETAILS 3

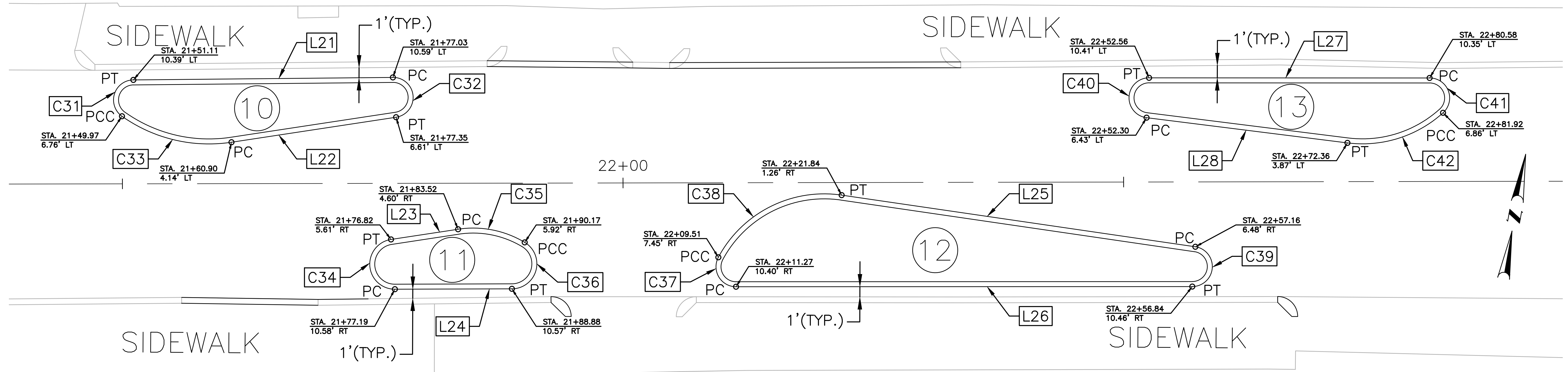

CHICANE NO.10 - NO.13

SCALE: 1" = 5'

CHICANE AREAS	*INTERIOR AREA [SQ FT]	**EXTERIOR AREA [SQ FT]
CHICANE 10	122.42	222.43
CHICANE 11	67.23	128.63
CHICANE 12	279.44	440.90
CHICANE 13	132.64	239.13

* INTERIOR AREA OF CHICANES, AREA DOES NOT INCLUDE THE CURBING.
 ** EXTERIOR AREA INCLUDES 1' FROM THE OUTSIDE FACE OF THE CURB AND INCLUDES THE INTERIOR AREA AND THE CURBING.

CHICANE: CURVE TABLE				
NO.	RADIUS	LENGTH	TANGENT	DELTA
C31	2.00'	5.03'	6.17'	144°05'04"
C32	2.00'	6.00'	28.26'	171°54'13"
C33	15.00'	11.52'	6.06'	044°00'42"
C34	2.50'	7.48'	33.68'	171°30'38"
C35	10.00'	6.92'	3.61'	039°39'07"
C36	2.50'	6.49'	8.97'	148°50'16"
C37	2.00'	4.12'	3.34'	118°09'49"
C38	12.00'	14.70'	8.43'	070°10'27"
C39	2.00'	5.97'	25.84'	171°08'49"
C40	2.00'	6.03'	32.09'	172°52'00"
C41	2.00'	4.81'	5.19'	137°49'42"
C42	12.00'	10.33'	5.51'	049°18'18"

CHICANE: LINE TABLE	
NO.	LENGTH
L21	25.92'
L22	16.63'
L23	6.77'
L24	11.69'
L25	35.70'
L26	45.57'
L27	28.02'
L28	20.22'

NOTE:
 ALL PROPOSED CHICANE ISLANDS SHALL HAVE 6" GRANITE SLOPE FACED CURB. [RI STD 7.4.0]

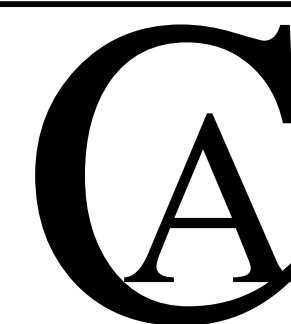

RA CATALDO & ASSOCIATES INC.

CIVIL ENGINEERS - LAND SURVEYORS

(401) 453-3300
 FAX: (401) 453-4117
 ca@cataldoeng.com

114 SMITHFIELD AVENUE
 PAWTUCKET, RHODE ISLAND 02860



CITY OF
CENTRAL FALLS

DESIGNED BY: RAC/CD
 CHECKED BY: RWC
 DATE: 08/20/2021
 SHEET: 15
 OF: 21

SCALE: 1"=5'



REVISIONS			REVISIONS		
NO.	DATE	BY	NO.	DATE	BY

INFRASTRUCTURE AND STREETSCAPE IMPROVEMENTS
SYLVIAN STREET

CENTRAL FALLS CONTRACT: 2021-0011 RHODE ISLAND

CHICANE DETAILS 4

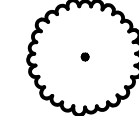
PLANT SCHEDULE CHICANE NO. 2

DECIDUOUS TREES	CODE	QTY	BOTANICAL / COMMON NAME	B&B	CALIPER
	GB	1	Ginkgo biloba 'Princeton Sentry' / Princeton Sentry Ginkgo 6'-8" STD.	B & B	2.5" Cal
PERENNIALS	CODE	QTY	BOTANICAL / COMMON NAME	CONT	
	HEM4	131	Heemerocallis hybrid 'Stella de Oro' / Stella de Oro Daylily	1 gal	18" o.c.

NOTE: ALL ISLANDS TO RECEIVE 8" LOAM AS PER RI STD SPECIFICATION L.01

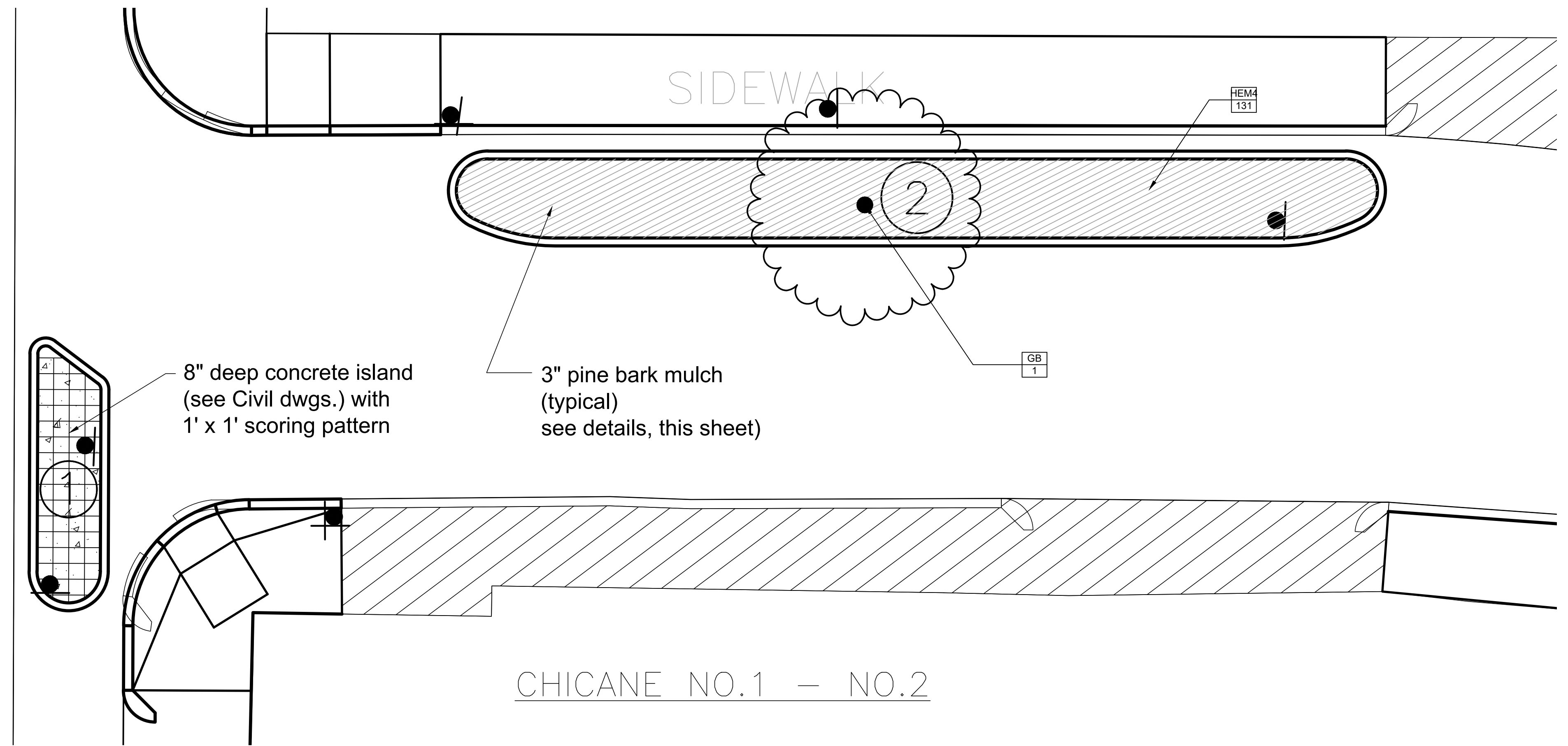

CHICANE NO. 2

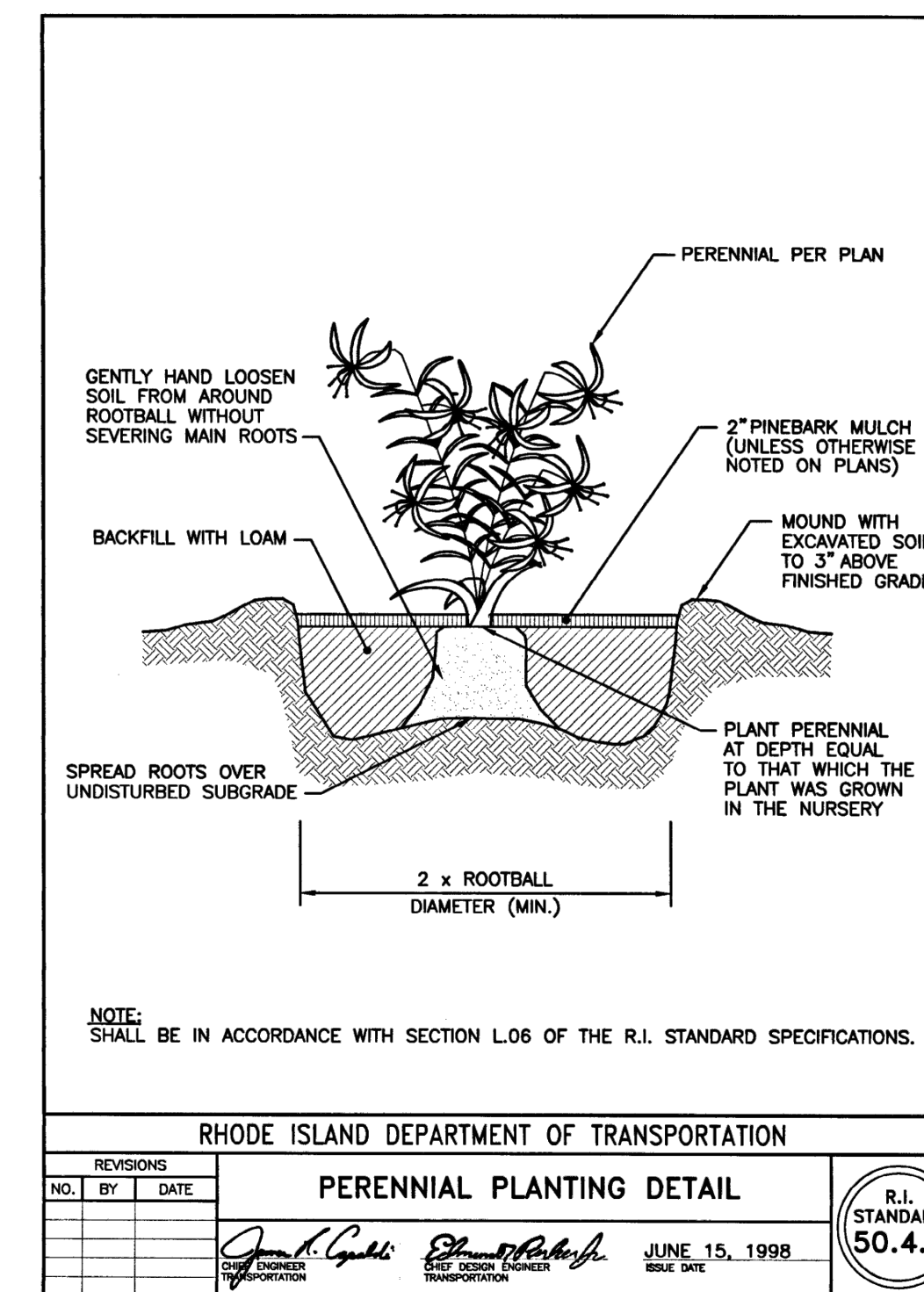
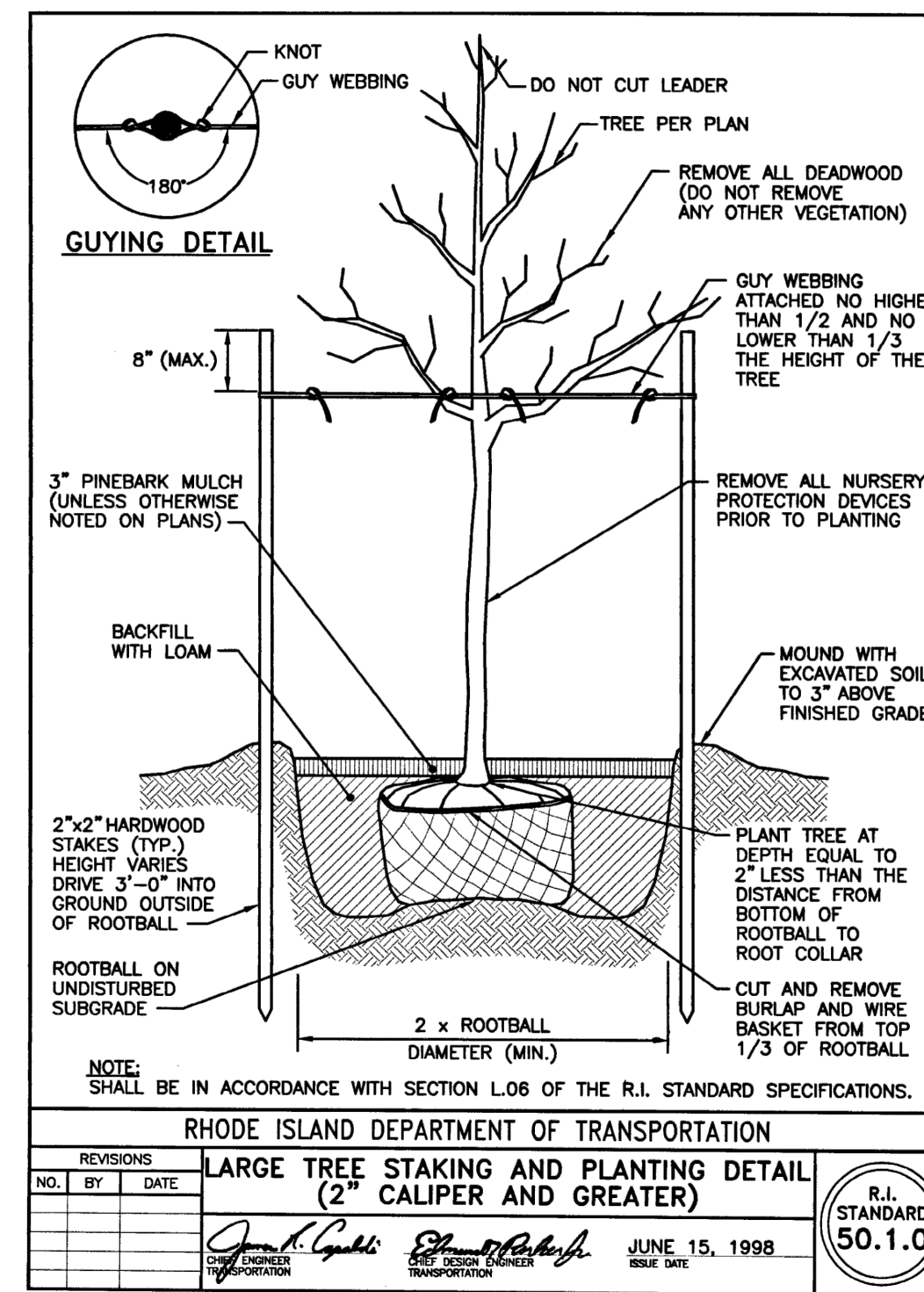

LOCATION OF EXISTING UTILITIES SHOWN, ARE FROM GATE LOCATION AND EXISTING DOCUMENTATION AND MAY NOT BE ACCURATE. EXACT LOCATION TO BE DONE BY THE APPROPRIATE UTILITY COMPANY OR MUNICIPALITY PRIOR TO ANY EXCAVATION CALL DIGSAFE AT: 1-888-DIG-SAFE

RA CATALDO & ASSOCIATES INC.
 CIVIL ENGINEERS - LAND SURVEYORS
 (401) 453-3300
 FAX: (401) 453-4117
 ca@cataldoeng.com
 114 SMITHFIELD AVENUE
 PAWTUCKET, RHODE ISLAND 02880



CITY OF
 CENTRAL FALLS



DESIGNED BY: DCS
 CHECKED BY: DCS
 DATE: 08/20/21
 SHEET: 16
 OF: 21

SCALE: 1"=5'

REVISIONS		REVISIONS	
NO.	DATE	NO.	DATE

INFRASTRUCTURE AND STREETScape IMPROVEMENTS
SYLVIAN STREET
 CENTRAL FALLS CONTRACT: 2021-0011 RHODE ISLAND
CHICANE LANDSCAPE 1

Diane C. Soule & Associates, ASLA
 Landscape Architecture
 422 Farnum Pike
 Smithfield, Rhode Island 02917
 www.dianesouleandassociates.com
 401.231.0738
 email: diane@dcsa.ws

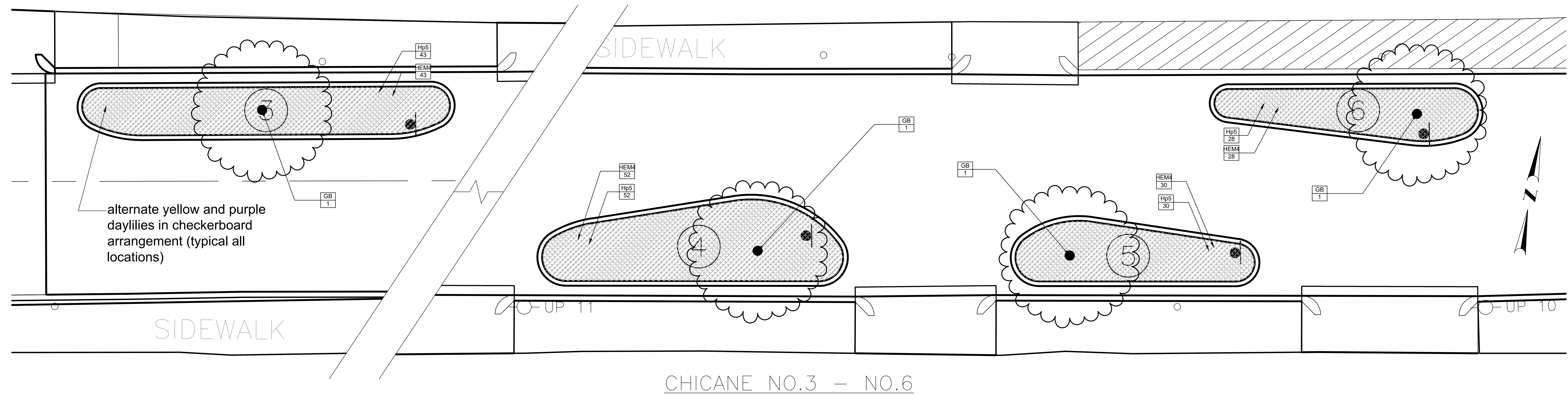

CHICANE NO.3 – NO.6

PLANT SCHEDULE CHICANE NO. 3 - 6

DECIDUOUS TREES	CODE	QTY	BOTANICAL / COMMON NAME	B&B	CALIPER
	GB	4	Ginkgo biloba 'Princeton Sentry' / Princeton Sentry Ginkgo	B & B	2.5" Cal
PERENNIALS	CODE	QTY	BOTANICAL / COMMON NAME	CONT	
	HEM4	153	Hemerocallis hybrid 'Stella de Oro' / Stella de Oro Daylily	1 gal	18" o.c.
	Hp5	153	Hemerocallis x 'Purple De Oro' / Purple De Oro Daylily	1 gal	18" o.c.

NOTE: ALL ISLANDS TO RECEIVE 8" LOAM AS PER RI STD SPECIFICATION L.01



CHICANE NO. 3 - 6



LOCATION OF EXISTING UTILITIES SHOWN, ARE FROM GATE LOCATION AND EXISTING DOCUMENTATION AND MAY NOT BE ACCURATE. EXACT LOCATION TO BE DONE BY THE APPROPRIATE UTILITY COMPANY OR MUNICIPALITY PRIOR TO ANY EXCAVATION CALL DIGSAFE AT: 1-888-DIG-SAFE 1-888-344-7233

Diane C. Soule & Associates, ASLA
Landscape Architecture
422 Farnum Pike
Smithfield, Rhode Island 02917
www.dianesouleandassociates.com
401.231.0738
email: diane@dcsa.ws

RA CATALDO & ASSOCIATES INC.
CIVIL ENGINEERS - LAND SURVEYORS
(401) 453-3300
FAX: (401) 453-4117
ca@cataldoeng.com
114 SMITHFIELD AVENUE
PAWTUCKET, RHODE ISLAND 02860



CITY OF
CENTRAL FALLS



DESIGNED BY: DCS
CHECKED BY: DCS
DATE: 08/20/2021
SHEET: 17
OF: 21

SCALE: 1"=5'

REVISIONS			REVISIONS		
NO.	DATE	BY	NO.	DATE	BY

INFRASTRUCTURE AND STREETSCAPE IMPROVEMENTS
SYLVIAN STREET
CENTRAL FALLS CONTRACT: 2021-0011 RHODE ISLAND
CHICANE LANDSCAPE 2

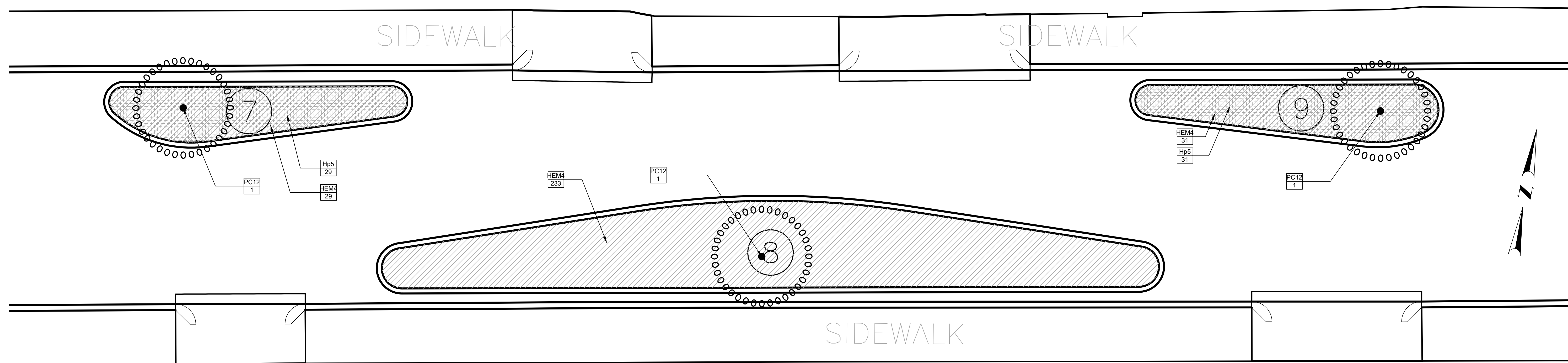

CHICANE NO.7 – NO.9

PLANT SCHEDULE CHICANE NO. 7 - 9

FLOWERING TREES	CODE	QTY	BOTANICAL / COMMON NAME	B&B	CALIPER
	PC12	3	Prunus sargentii 'Columnaris' / Columnar Sargent Cherry 6'-8" STD.	B & B	2.5"Cal
PERENNIALS	CODE	QTY	BOTANICAL / COMMON NAME	CONT	
	HEM4	293	Hemerocallis hybrid 'Stella de Oro' / Stella de Oro Daylily	1 gal	18" o.c.
	Hp5	60	Hemerocallis x 'Purple De Oro' / Purple De Oro Daylily	1 gal	18" o.c.

NOTE: ALL ISLANDS TO RECEIVE 8" LOAM AS PER RI STD SPECIFICATION L.01

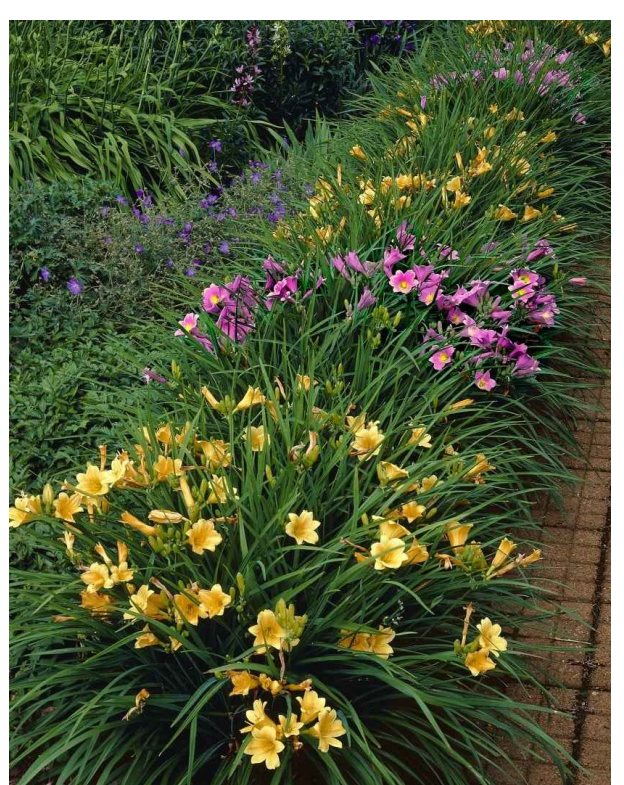

CHICANE NO. 7 - 9



CHICANE NO. 8



LOCATION OF EXISTING UTILITIES SHOWN, ARE FROM GATE LOCATION AND EXISTING DOCUMENTATION AND MAY NOT BE ACCURATE. EXACT LOCATION TO BE DONE BY THE APPROPRIATE UTILITY COMPANY OR MUNICIPALITY PRIOR TO ANY EXCAVATION CALL DIGSAFE AT: 1-888-DIG-SAFE

RA CATALDO & ASSOCIATES INC.
 CIVIL ENGINEERS - LAND SURVEYORS
 (401) 453-3300
 FAX: (401) 453-4117
 ca@cataldoeng.com
 114 SMITHFIELD AVENUE
 PAWTUCKET, RHODE ISLAND 02860



CITY OF
 CENTRAL FALLS



DESIGNED BY: DCS
 CHECKED BY: DCS
 DATE: 08/20/2021
 SHEET: 18
 OF: 21

SCALE: 1"=5'

REVISIONS			REVISIONS		
NO.	DATE	BY	NO.	DATE	BY

INFRASTRUCTURE AND STREETSCAPE IMPROVEMENTS
SYLVIAN STREET
 CENTRAL FALLS CONTRACT: 2021-0011 RHODE ISLAND
CHICANE LANDSCAPE 3

Diane C. Soule & Associates, ASLA
 Landscape Architecture
 422 Farnum Pike
 Smithfield, Rhode Island 02917
 www.dianesouleandassociates.com
 401.231.0738
 email: diane@dcsa.ws

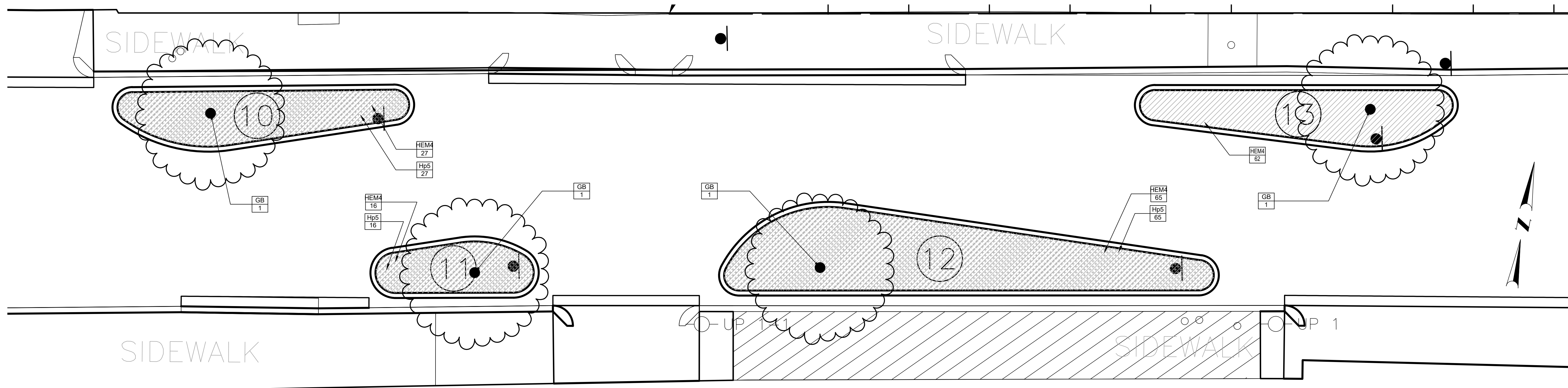

CHICANE NO.10 – NO.13

PLANT SCHEDULE CHICANE NO. 10 - 13

DECIDUOUS TREES	CODE	QTY	BOTANICAL / COMMON NAME	B&B	CALIPER
	GB	4	Ginkgo biloba 'Princeton Sentry' / Princeton Sentry Ginkgo 6'-8" STD.	B & B	2.5" Cal
PERENNIALS	CODE	QTY	BOTANICAL / COMMON NAME	CONT	
	HEM4	170	Hemerocallis hybrid 'Stella de Oro' / Stella de Oro Daylily	1 gal	18" o.c.
	Hp5	108	Hemerocallis x 'Purple De Oro' / Purple De Oro Daylily	1 gal	18" o.c.

NOTE: ALL ISLANDS TO RECEIVE 8" LOAM AS PER RI STD SPECIFICATION L.01



CHICANE NO. 10 - 12



CHICANE NO. 13



LOCATION OF EXISTING UTILITIES SHOWN, ARE FROM GATE LOCATION AND EXISTING DOCUMENTATION AND MAY NOT BE ACCURATE. EXACT LOCATION TO BE DONE BY THE APPROPRIATE UTILITY COMPANY OR MUNICIPALITY PRIOR TO ANY EXCAVATION CALL DIGSAFE AT: 1-888-DIG-SAFE 1-888-344-7233

RA CATALDO & ASSOCIATES INC.
 CIVIL ENGINEERS - LAND SURVEYORS
 (401) 453-3300
 FAX: (401) 453-4117
 ca@cataldoeng.com
 114 SMITHFIELD AVENUE
 PAWTUCKET, RHODE ISLAND 02860



CITY OF
 CENTRAL FALLS



DESIGNED BY: DCS
 CHECKED BY: DCS
 DATE: 08-20-2021
 SHEET: 19
 OF: 21

SCALE: 1"=5'
 GRAPHIC SCALE
 REVISIONS

NO.	DATE	BY	NO.	DATE	BY

INFRASTRUCTURE AND STREETSCAPE IMPROVEMENTS
 SYLVIAN STREET
 CONTRACT: 2021-0011
 CHICANE LANDSCAPE 4
 CENTRAL FALLS RHODE ISLAND

Diane C. Soule & Associates, ASLA
 Landscape Architecture
 422 Farnum Pike
 Smithfield, Rhode Island 02917
 www.dianesouleandassociates.com
 401.231.0736
 email: diane@dcsa.ws



Issue Date: 1/6/17
Revised: 6/14/19

PROVIDENCE WHEELCHAIR RAMP STANDARDS

The City of Providence has adopted the Rhode Island Department of Transportation's (RIDOT) wheelchair ramp standards:

43.3.0 - Wheelchair Ramp
43.3.1 - Wheelchair Ramp for Limited Right-of-Way Areas
43.3.2 - Ramp/Landing for Narrow Sidewalk
48.1.0 - Detectable Warning Panel Placement

Please note:

- All sidewalks and wheelchair ramps shall be Portland cement concrete.
- All references to curbing in the RIDOT standard details shall be Providence Standard 7" wide granite curb

DEPARTMENT OF PUBLIC WORKS
700 Adams Avenue Providence, Rhode Island 02905
401 467 7950 ph | 401 941 2567 fax
www.providenceri.com

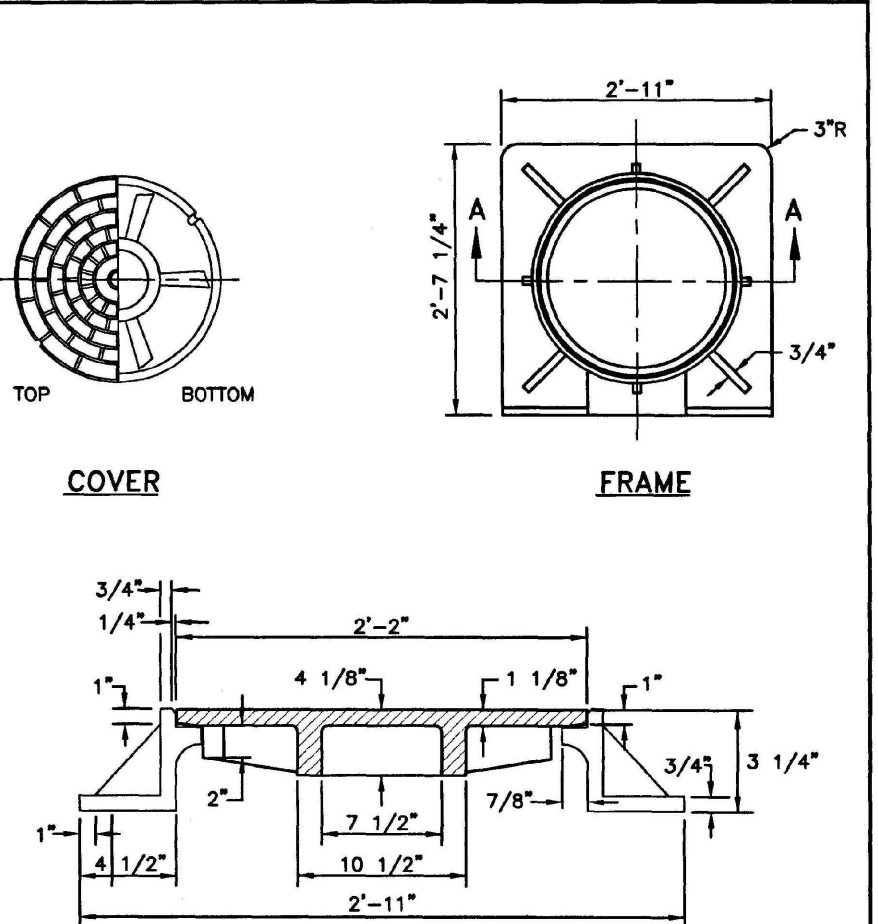

COVER **FRAME**

SECTION A-A

NOTES:
1. FRAME AND COVER SHALL CONFORM TO SECTION M.04 OF THE R.I. STANDARD SPECIFICATIONS
2. FRAME AND COVER SEATS TO BE MACHINE FINISH.

RHODE ISLAND DEPARTMENT OF TRANSPORTATION
HEAVY-DUTY SQUARE FRAME AND ROUND COVER
N.T.S.

7.3.0 P
PROVIDENCE STANDARD
6.1.1

REVISIONS
NO. BY DATE

JUNE 15, 1998
ISSUE DATE

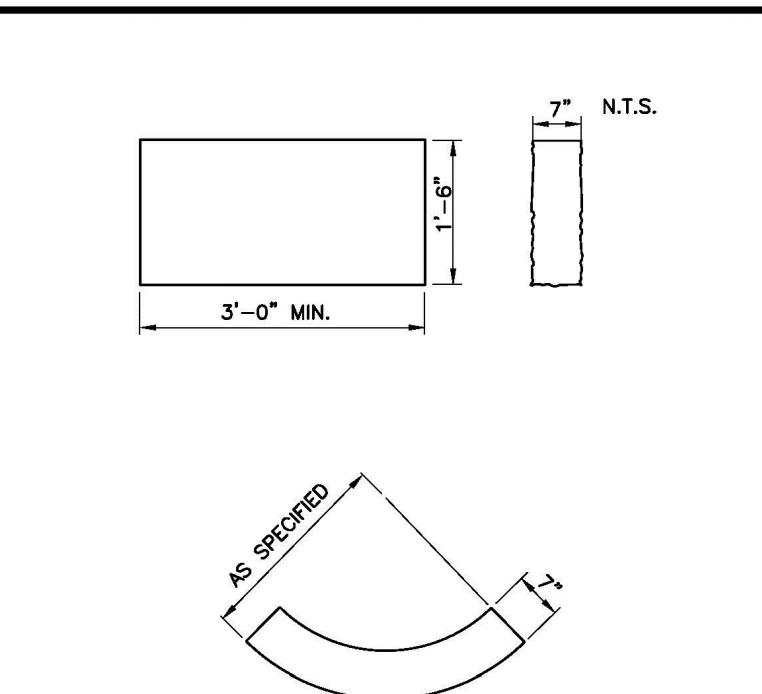

GRANITE CURB - STRAIGHT AND CIRCULAR
N.T.S.

7.3.0 P
PROVIDENCE STANDARD

NOTE:
1. SHALL BE IN ACCORDANCE WITH SECTION 906 OF THE R.I. STANDARD SPECIFICATIONS.
2. TOP SURFACE TO BE DRESSED BY SAW. REMAINDER TO BE SAWCUT OR QUARRY SPLIT.
3. MINIMUM LENGTH OF STRAIGHT OR CIRCULAR PIECES TO BE 3'-0".
4. CIRCULAR CURB IS REQUIRED ON CURVES AS INDICATED.
5. CURB TO BE SET PER PROVIDENCE CURB SETTING DETAIL.

ISSUE DATE: 1/6/17

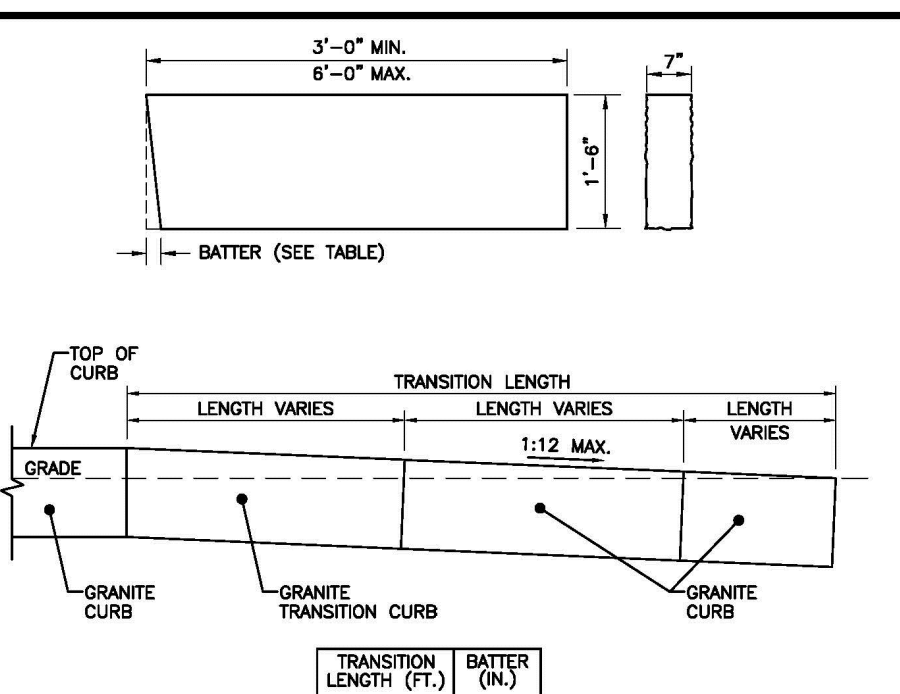

GRANITE WHEELCHAIR RAMP TRANSITION CURB
N.T.S.

7.3.3 P
PROVIDENCE STANDARD

NOTES:
1. SHALL BE IN ACCORDANCE WITH SECTION 906 OF THE R.I. STANDARD SPECIFICATIONS.
2. THE CONTRACTOR MAY CUT EXISTING CURB SECTIONS AS REQUIRED TO MEET THIS DETAIL AND THE R.I. STANDARD SPECIFICATIONS, WHERE OLD CURBING IS BEING REUSED.
3. MINIMUM LENGTH OF STRAIGHT OR CIRCULAR CURB FILLER PIECES TO BE 3'-0" (GREATER LENGTHS PREFERRED).
4. TOP SURFACE TO BE DRESSED BY SAW. REMAINDER TO BE SAWCUT OR QUARRY SPLIT.
5. CURB TO BE SET PER PROVIDENCE CURB SETTING DETAIL.

TRANSITION LENGTH (FT.)	BATTER (IN.)
6.0	1.5
7.0	1.3
8.0	1.2
9.0	1.0
10.0	0.8
12.0	0.6
18.0	0.5

ISSUE DATE: 1/6/17

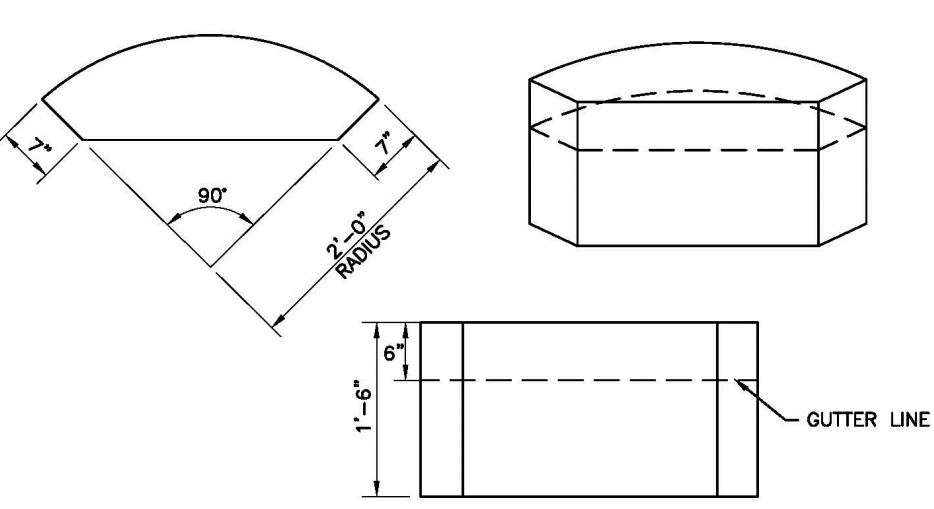

GRANITE 2'-0" RADIUS CURB RETURN
N.T.S.

7.3.4 P
PROVIDENCE STANDARD

NOTES:
1. SHALL BE IN ACCORDANCE WITH SECTION 906 OF THE R.I. STANDARD SPECIFICATIONS.
2. TOP SURFACE TO BE DRESSED BY SAW. REMAINDER TO BE QUARRY SPLIT OR SAWCUT.

ISSUE DATE: 1/6/17

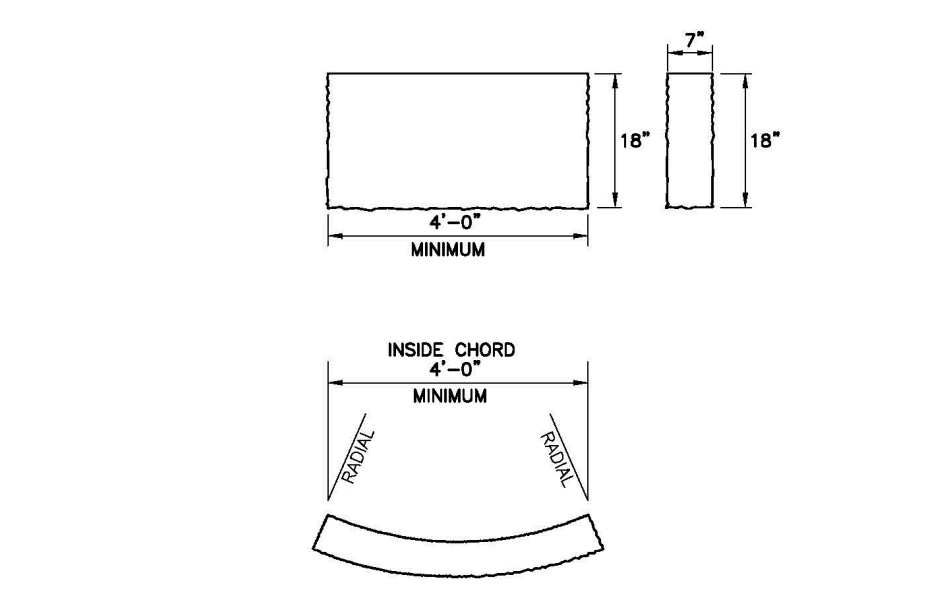

GRANITE RAMP STONE
N.T.S.

7.3.8 P
PROVIDENCE STANDARD

NOTES:
1. SHALL BE IN ACCORDANCE WITH SECTION 906 OF THE R.I. STANDARD SPECIFICATIONS.
2. TOP SURFACE TO BE DRESSED BY SAW TO PROVIDE NO-SLIP SURFACE; REMAINDER MAY BE QUARRY SPLIT.
3. MINIMUM LENGTH OF STRAIGHT OR CIRCULAR CURB FILLER PIECES TO BE 4'-0".
4. CIRCULAR RAMP STONE IS REQUIRED ON CURVES AS INDICATED.
5. RAMP STONE SHALL BE SET IN ACCORDANCE WITH PROVIDENCE CURB SETTING STANDARD.

ISSUE DATE: 1/6/17

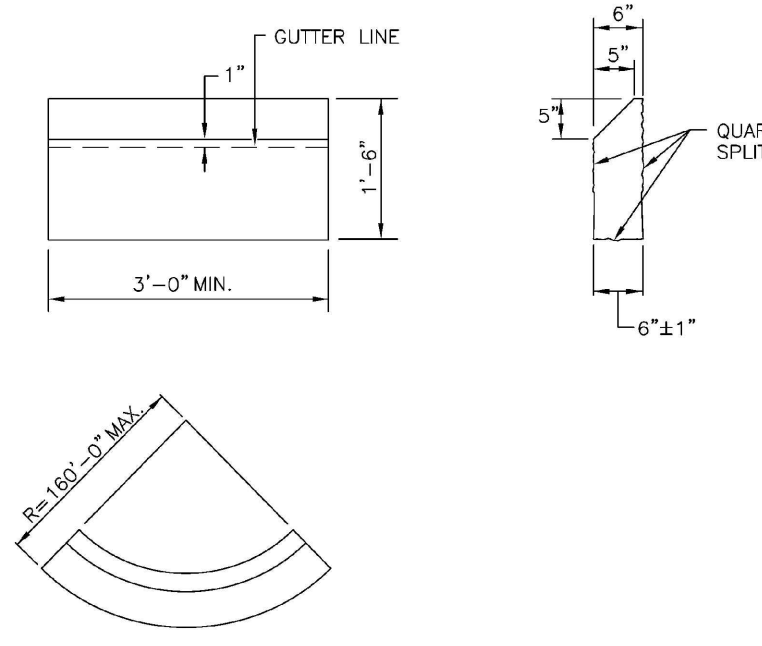

GRANITE SLOPED FACE CURB
N.T.S.

7.4.0 P
PROVIDENCE STANDARD

NOTES:
1. SHALL BE IN ACCORDANCE WITH SECTION 906 OF THE R.I. STANDARD SPECIFICATIONS.
2. TOP SURFACE AND SLOPED SURFACE TO BE DRESSED BY SAW. REMAINDER TO BE QUARRY SPLIT.
3. MINIMUM LENGTH OF STRAIGHT OR CIRCULAR PIECES TO BE 3'-0".
4. CIRCULAR CURB IS REQUIRED ON CURVES WITH RADIUS OF 160'-0" OR LESS. STRAIGHT CURB TO BE USED ON CURVES OF MORE THAN 160'-0" RADIUS.

ISSUE DATE: 1/6/17

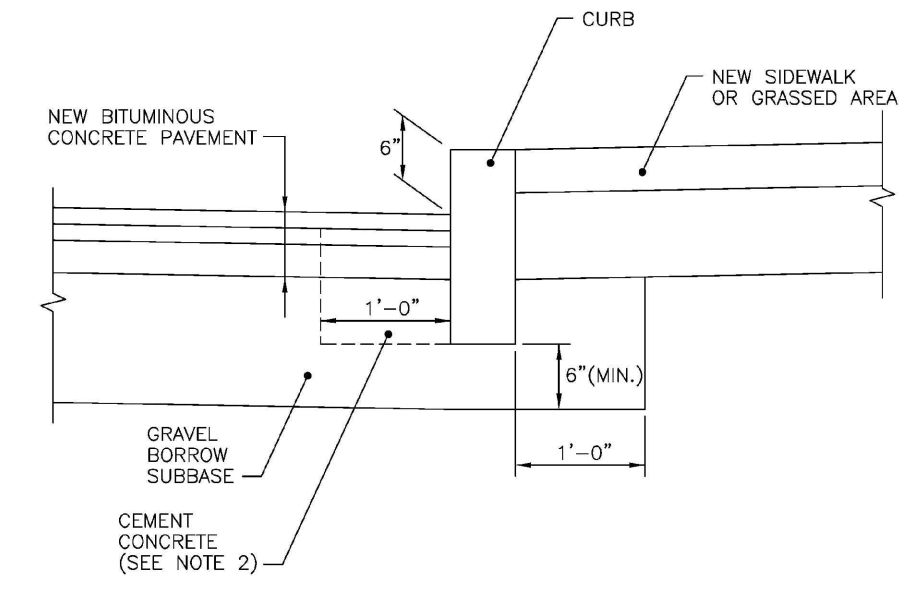

CURB SETTING DETAIL
N.T.S.

7.5.0 P
PROVIDENCE STANDARD

NOTES:
1. SHALL BE IN ACCORDANCE WITH SECTION 906 OF THE R.I. STANDARD SPECIFICATIONS.
2. CEMENT CONCRETE SHALL BE USED ONLY WHEN THE CURB IS SET AFTER THE BASE AND/OR BINDER COURSES ARE IN PLACE. OTHERWISE THE CEMENT CONCRETE WILL BE ELIMINATED AND THE GRAVEL BROUGHT UP TO BOTTOM OF THE BASE COURSE.

ISSUE DATE: 1/6/17

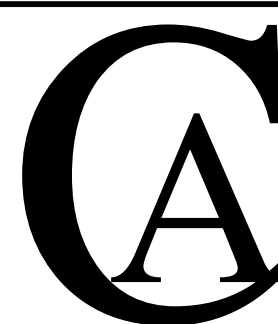

RA CATALDO & ASSOCIATES INC.
CIVIL ENGINEERS - LAND SURVEYORS

(401) 453-3300
FAX: (401) 453-4117
ca@cataldoeng.com

114 SMITHFIELD AVENUE
PAWTUCKET, RHODE ISLAND 02880



CITY OF CENTRAL FALLS

DESIGNED BY: RAC/ CD
CHECKED BY: RWC
DATE: 08/20/2021
SHEET: 20
OF: 21

SCALE: NO SCALE

REVISIONS		REVISIONS	
NO.	DATE	NO.	DATE

INFRASTRUCTURE AND STREETScape IMPROVEMENTS
SYLVIAN STREET
CENTRAL FALLS CONTRACT: 2021-0011 RHODE ISLAND
DETAILS 1

